

M 182921-1



Proseguire nella pagina successiva per visualizzare la scheda tecnica dei componenti

Revisione	Prodotto
REV.01 16/04/2026	OEM

THIS DRAWING IS UNPUBLISHED. — RELEASED FOR PUBLICATION —
 © COPYRIGHT — By — ALL RIGHTS RESERVED.

LOC	DIST	REVISIONS			
P	LTR	DESCRIPTION	DATE	DWN	APVD
—	—	M4	REVISED PER ECO-11-005301	02MAR11	RK HMR

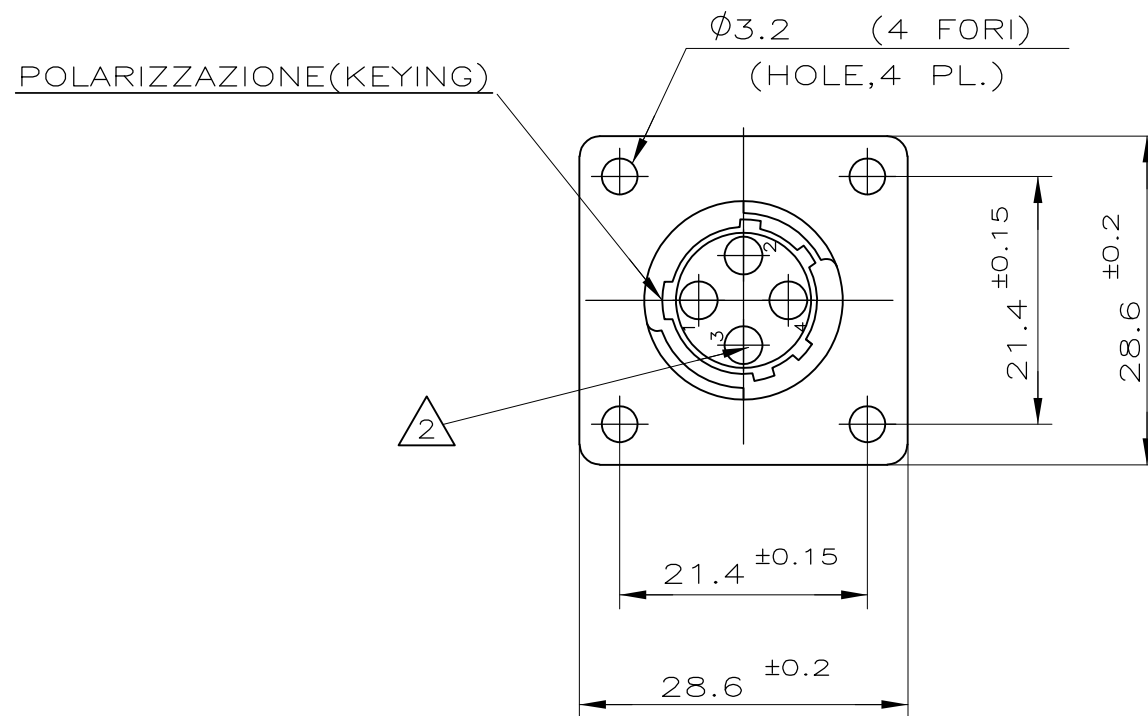
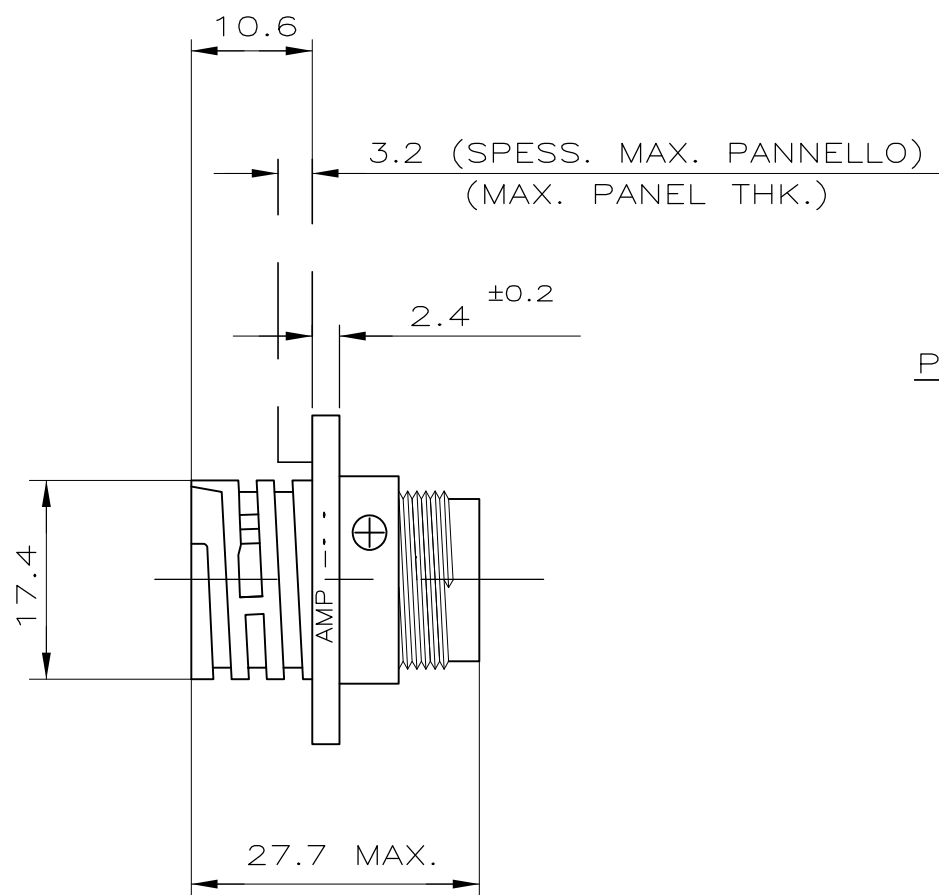

NOTE(NOTES)

1. MATERIALE(MATL.): TERMOPLASTICO COLORE NERO(THERMOPLASTIC, BLACK COLOR).

2. OGNI CAVITA' E' IDENTIFICATA DAL NUMERO POSTO SIA SUL FRONTE CHE SUL RETRO DEL CONNETTORE. (CONTACT CAVITIES IDENTIFIED BY CHARACTERS) (ON FRONT AND REAR FACES OF CONNECTOR.)

3. QUESTO CONNETTORE E' APPROVATO CON FILE N.E28476 E CERTIFICATO CON FILE N.LR7189A-259 (THIS CONNECTOR IS RECOGNIZED BY FILE N.E28476 AND CERTIFIED BY FILE N.LR7189A-259)

IL DISEGNO INDICA IL P.N. 182921-1 (P.N. 182921-1 AS SHOWN)

THIS DRAWING IS A CONTROLLED DOCUMENT.		DWN C.CORDOLA	22JUN1991	TE Connectivity	
DIMENSIONS: mm		CHK C.CORDOLA	22JUN1991		
TOLERANCES UNLESS OTHERWISE SPECIFIED: ±0.3		APVD —		NAME C.P.C. SQUARE FLANGE RECEPTACLE FOR SOCKET CONTACTS, SIZE 11-4, REV. SEX	
0 PLC ± - 1 PLC ± - 2 PLC ± - 3 PLC ± - 4 PLC ± - ANGLES ± 2'		PRODUCT SPEC —		SIZE A3	
MATERIAL —		APPLICATION SPEC —		CAGE CODE 00779	
FINISH —		WEIGHT —		DRAWING NO C-182921	
CUSTOMER DRAWING				SCALE —	SHEET 1 OF 1
				REV M4	RESTRICTED TO —