

# M 2-1418483-1K

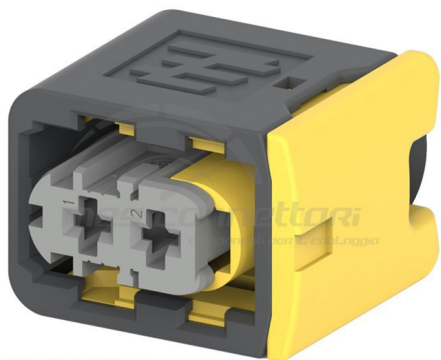

MINIKIT

*Proseguire nella pagina successiva per visualizzare la scheda tecnica dei componenti*

Revisione	Prodotto
REV.00 14/04/2026	OEM



NUMMER	828904
VERWENDET FÜR	
WAR NR.	87-9398-50

ÄNDERUNGEN, DIE DEM  
TECHNISCHEN FORT-  
SCHRITT DIENEN, BE-  
HALTEN WIR UNS VOR

REVISIONS				
P	LTR	DESCRIPTION	DATE	APVD
	M5	Alternate CAV.ID format added.	11NOV2025	BV GB

M 1:1

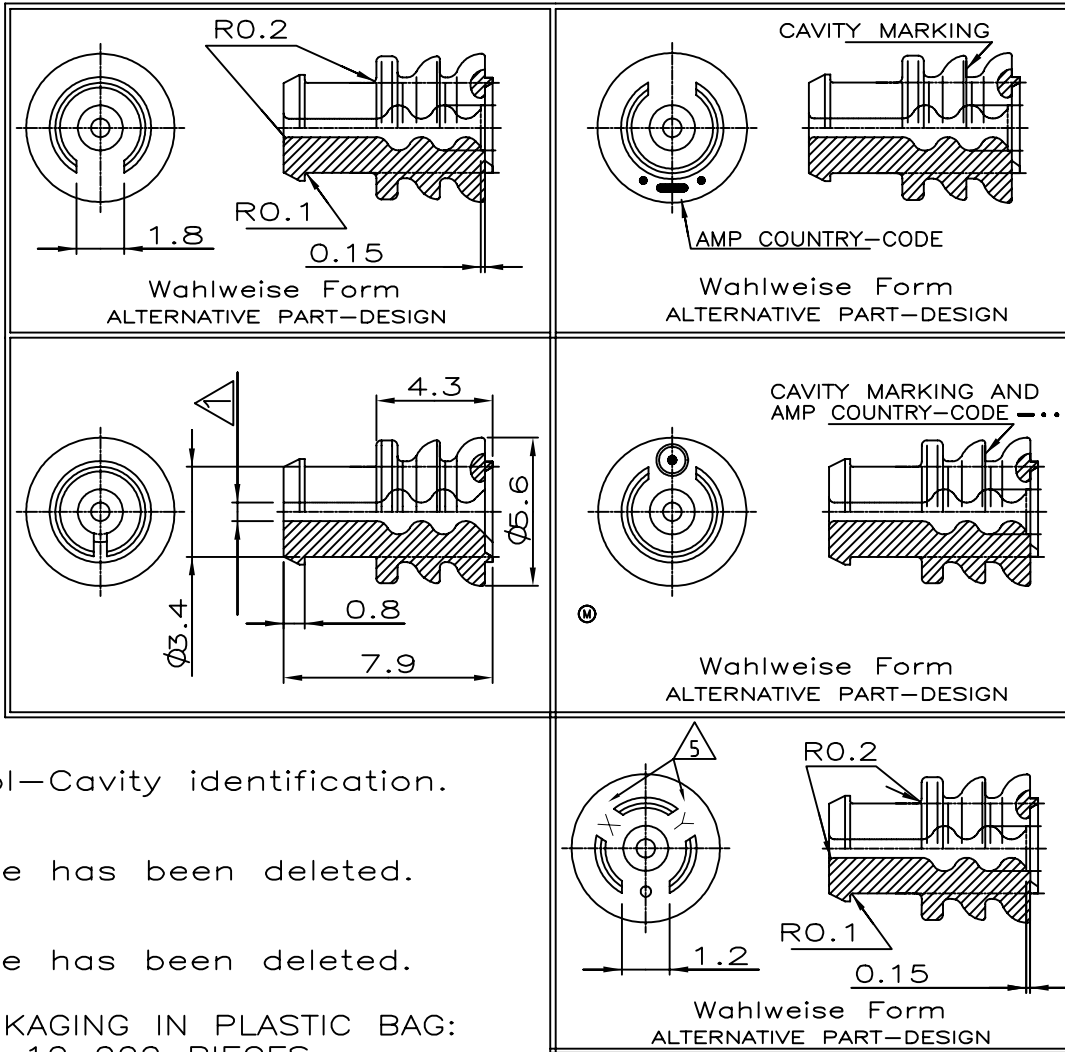

- 5 Tool-Cavity identification.
- 4 Note has been deleted.
- 3 Note has been deleted.
- 2 PACKAGING IN PLASTIC BAG:  
QTY 10 000 PIECES
- 1 Für Isolationsø 1.2-2.1 mm

TE Connectivity. All Rights Reserved.

828904-3	4	M	SILICON SHORE A 50 <sup>+</sup> lubriziert	hellblau
828904-2	3	M		
828904-1	2	M		

CAD-ORIGINAL  
ZEICHNUNG NICHT ÄNDERN

Ⓢ	BESTELL-NR.	REV	WERKSTOFF	OBERFLÄCHE FARBE	ZEICHNUNG GÜLTIG AB .....			
DIMENSIONS: mm			DWN H.Bouda	16 MAY 88	MATERIAL	FINISH		
TOLERANCES UNLESS OTHERWISE SPECIFIED:			CHK W. PFEFFER	17 MAY 88	TE Connectivity			
0 PLC ± - 1 PLC ± 0.3 2 PLC ± - 3 PLC ± - 4 PLC ± - ANGLES ± -			APVD -	PRODUCT SPEC -				
			APPLICATION SPEC -	WEIGHT 0,000000	SIZE A4	CAGE CODE 00779	DRAWING NO C-828904	RESTRICTED TO -
			CUSTOMER DRAWING		SCALE 5:1	SHEET 1 OF 1	REV M5	