

M 22907-C

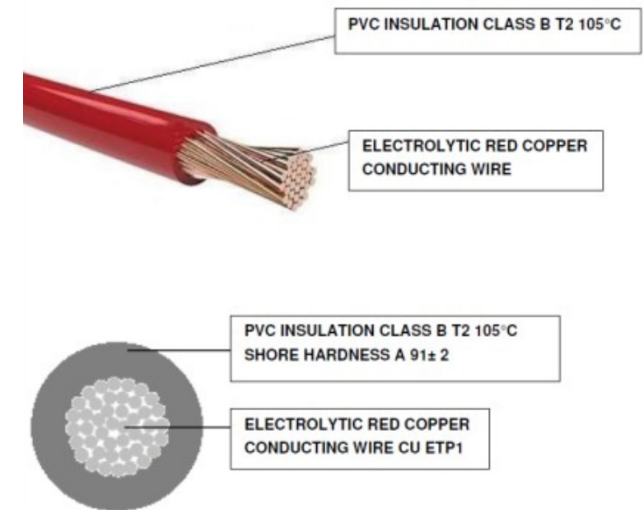

Caratteristiche CAVO	
Temperatura d'uso	-40 °C / +105 °C (IDLE STATE)
Sezione	0.50 mmq
Colore	Bianco
Documenti di riferimento	ISO 19642 : 2019 / DIN 72551 ISO 6722 CLASS B / LV 112 / ISO 3795 FIAT 91107 / 18 (where applicable) ROHS II/III UN R118
Lunghezza	20 cm
Tipologia	F3T2



CROSS SECTION	COND. CONSTR.	EXT. DIAMETER.	INSUL. MATERIAL	EL. RES. MAX 20°	MAX VOLT.	INSULATION THICKNESS (+)
1 x 1,00	32 x 0,20 ± 0,01 mm	2,10 +0 mm -0,2 mm	PVC T2 HT 105 °C	18,5 OHM/KM	< 300 V	≥ 0,24

Proseguire nella pagina successiva per visualizzare la scheda tecnica dei componenti

Revisione	Prodotto
REV.00 08/04/2026	OEM

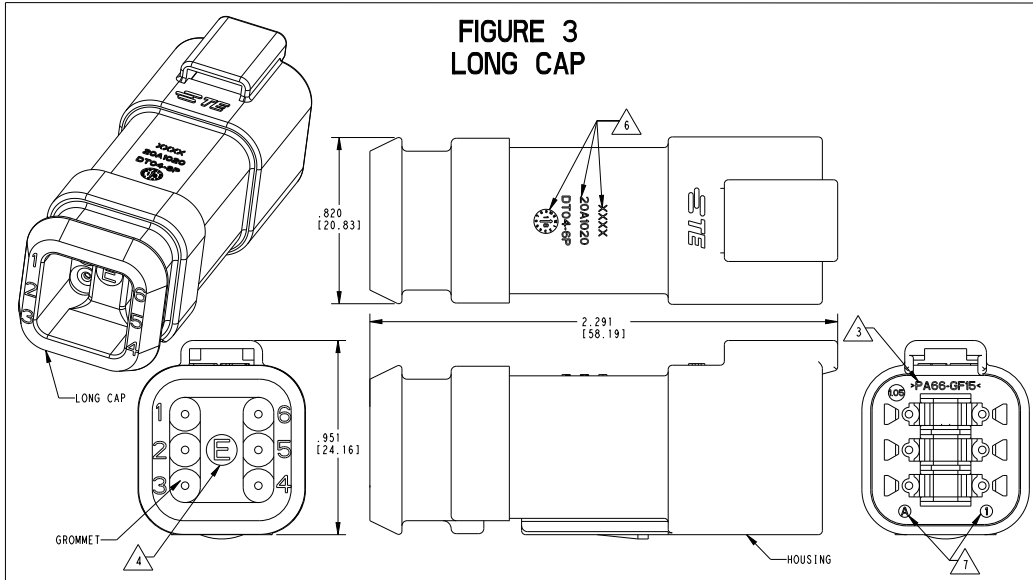
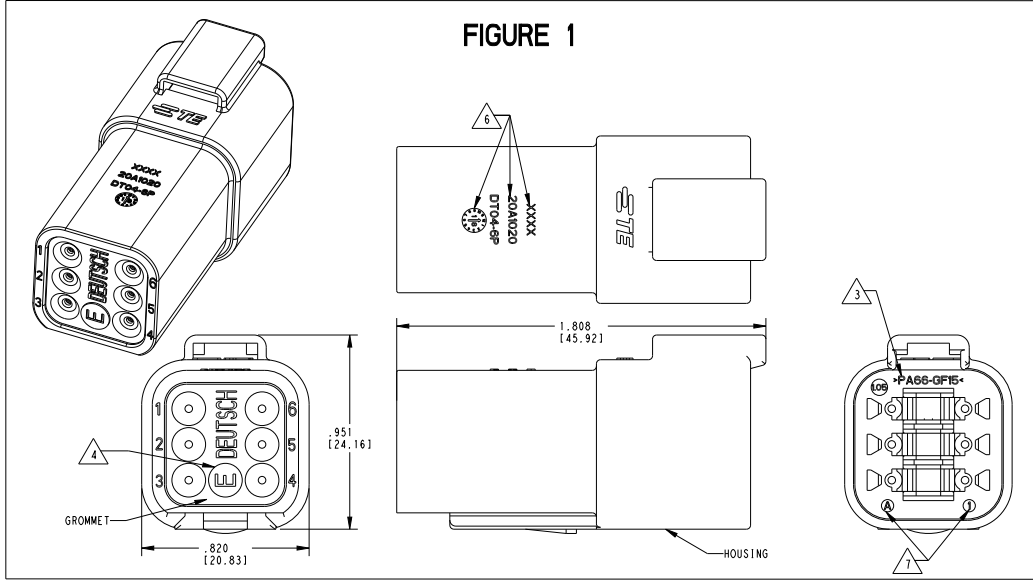

△ MARKING FOR PARTS PRODUCED IN CHINA:

- XXXX IDENTIFIES THE MODIFICATION NUMBER. IF APPLICABLE, EXAMPLE: "E003" FOR DT04-6P-E003, OR BLANK FOR DT04-6P
- DATE CODE: IDENTIFIES THE YEAR, MONTH, DAY AND HOUR OF ASSEMBLY. YEAR: FIRST AND SECOND DIGIT. (17 = 2017) MONTH: THIRD DIGIT, EXCLUDING 1. A = JAN, B = FEB, C = MARCH, ... (K = OCTOBER)
- DIAL DATE CODE LOCATED ON HOUSING AND/OR CAP. -CN LOCATED ON HOUSING AND/OR CAP.

△ MATERIAL: HOUSING: PA66 GF15, SEE TABLE FOR COLOR SHORT; LONG CAP: PA66 GF15, BLACK GROMMET: E-SEAL VMO (BURNT RED), N-SEAL VMO (RED-ORANGE) BLOCKED VMO (RED-ORANGE)

2. THIS RECEPTACLE MATES WITH DT06-6S-XXXX PLUG (XXXX = ALL MODIFICATIONS)

1. SECONDARY WEDGE LOCK SOLD SEPARATELY: W6P-XXXX. (XXXX = ALL MODIFICATIONS)

5. FOR CONTACT AND WIRE PERFORMANCE AND APPLICATION CHARACTERISTICS SEE CUSTOMER DRAWING 0425-015-0000.

8. FOR ALL ID MARKINGS SURROUNDING THE PART, ORIENTATION IS SHOWN FOR REFERENCE ONLY AND DOES NOT AFFECT FUNCTIONALITY, PROVIDED THE MARKINGS ARE IN THE CORRECT POSITION. SIZE AND LOCATION ARE APPROXIMATE, AS SHOWN.

△ MARKING FOR PARTS PRODUCED IN US:

- DATE CODE: YEAR TO BE LAST NUMERICAL DIGIT, EX: 1 = 2021 MONTH USES SEQUENTIAL ALPHA CHARACTERS, EX: A = JANUARY -DEUTSCH

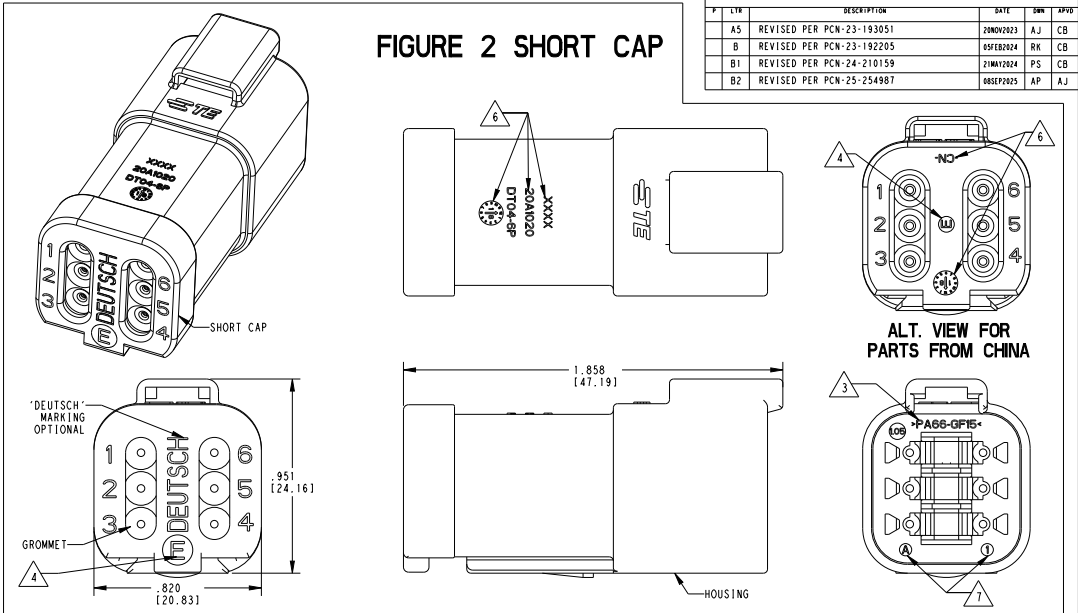

REVISIONS				
P	LT#	DESCRIPTION	DATE	BY
A5		REVISED PER PCN-23-193051	20M02023	AJ CB
B		REVISED PER PCN-23-192205	05F02024	RK CB
B1		REVISED PER PCN-24-210159	21M12024	PS CB
B2		REVISED PER PCN-25-254907	08E02025	AP AJ

CONTACT SIZE	WIRE RANGE	INSULATION OD SEALING RANGE	SEAL IDENTIFICATION
16	14-20 AWG [2.5-0.5mm ²]	.088-.145 [2.23-3.68]	STANDARD SEAL
		.053-.120 [1.35-3.05]	EXTRA THIN SEAL E-SEAL

TE INTERNAL PART NUMBER	DEUTSCH PART NUMBER	PN REV	HOUSING COLOR	STANDARD SEAL	EXTRA THIN SEAL E-SEAL	BLOCKED SEAL	SHORT CAP	LONG CAP	FIGURE
DT04-6P	DT04-6P	A	GRAY	X					1
DT04-6P-C015	DT04-6P-C015	B	GRAY		X				1
DT04-6P-C017	DT04-6P-C017	B	GRAY			X	X		2
DT04-6P-CE01	DT04-6P-CE01	C	GRAY		X		X		2
DT04-6P-CE02	DT04-6P-CE02	B	BLACK		X				1
DT04-6P-CE03	DT04-6P-CE03	B	BLACK		X		X		2
DT04-6P-CE04	DT04-6P-CE04	B	GRAY		X			X	3
DT04-6P-CE09	DT04-6P-CE09	B	BLACK		X			X	3
DT04-6P-CE26	DT04-6P-CE26	A	BLACK			X	X		2
DT04-6P-E003	DT04-6P-E003	B	GRAY	X			X		2
DT04-6P-E004	DT04-6P-E004	A	BLACK	X					1
DT04-6P-E005	DT04-6P-E005	A	BLACK	X			X		2
DT04-6P-E008	DT04-6P-E008	B	GRAY	X				X	3
DT04-6P-EE01	DT04-6P-EE01	A	BLACK	X				X	3
DT04-6P-EP04	DT04-6P-EP04	C	GRAY	X			X		2
DT04-6P-P004	DT04-6P-P004	B	GRAY	X					1
1-2448114-1	DT04-6P-TE09	A	BROWN		X				1
1-2448114-2	DT04-6P-TE03	A	GREEN		X				1
1-2448114-3	DT04-6P-TE07	A	BLUE		X				1
2-2448114-1	DT04-6P-TN09	A	BROWN	X					1
2-2448114-2	DT04-6P-TN03	A	GREEN	X					1
2-2448114-3	DT04-6P-TN07	A	BLUE	X					1
3-2448114-1	DT04-6P-EE18	A	BROWN		X		X		2
3-2448114-2	DT04-6P-EE16	A	GREEN		X		X		2
3-2448114-3	DT04-6P-EE17	A	BLUE		X		X		2
4-2448114-1	DT04-6P-EE14	A	BROWN	X			X		2
4-2448114-2	DT04-6P-EE13	A	GREEN	X			X		2
4-2448114-3	DT04-6P-EE06	A	BLUE	X			X		2

THIS DRAWING IS A CONTROLLED DOCUMENT.

TE Connectivity
6 WAY RECEPTACLE, STANDARD SEAL EXTRA THIN SEAL, SHORT AND LONG CAP, DT SERIES

15DEC2021
15DEC2021
15DEC2021

108-151009
114-151009

44F08 DT04-6P-XXXX

CUSTOMER DRAWING SCALE 3:1 SHEET 1 OF 1

THIS DRAWING IS UNPUBLISHED. RELEASED FOR PUBLICATION 2020
 © COPYRIGHT 2020 BY TE CONNECTIVITY ALL RIGHTS RESERVED.

P	LTR	DESCRIPTION	DATE	DWN	APVD
K		REVISED PER PCN E-20-008101	12JUN2020	DM	DM
L		REVISED PER PCN-21-121539	08DEC2021	MK	DM
L1		REVISED PER PCN-21-121539	04FEB2022	MK	DM
L2		REVISED PER PCN-25-234384	30JAN2025	RK	CB

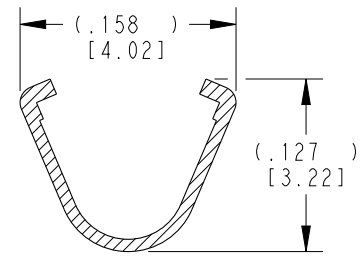
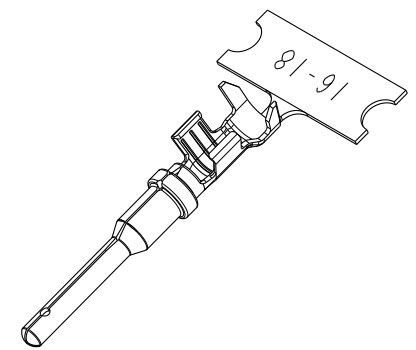
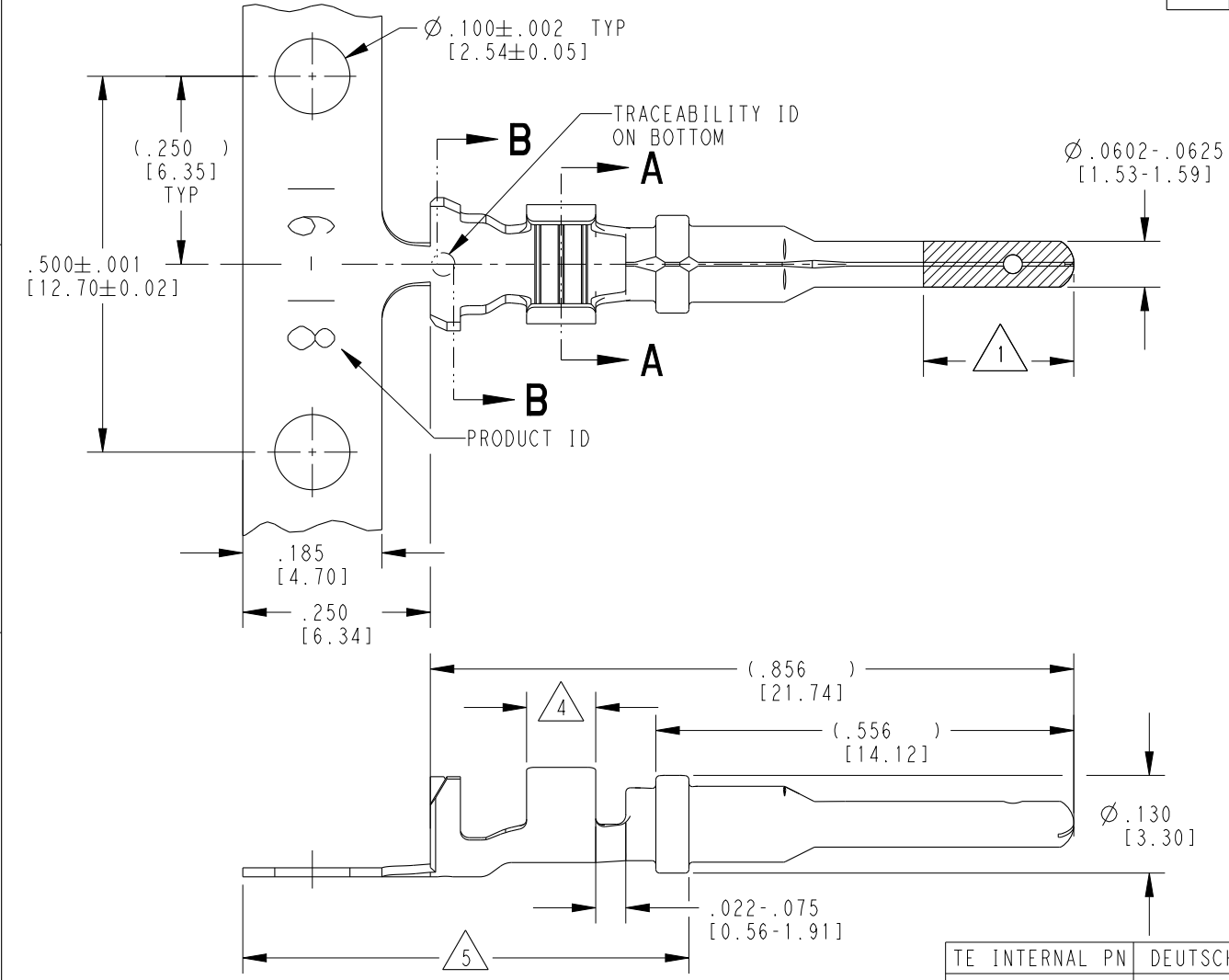

SECTION A-A
WIRE BARREL

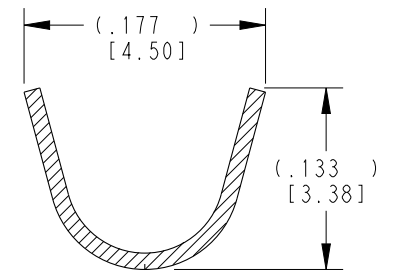

SECTION B-B
INSULATION BARREL

- 5 TIN PLATING MAY BE IN THIS REGION.
- 4 TIN PLATED REGION.
- 3 MATERIAL: .012 [0.30] THICK COPPER ALLOY
- 2. WIRE RANGE: 18 AWG TO 14 AWG [0.75-2.0 mm²]
INSULATION RANGE: Ø .075-.140 [Ø 1.91-3.56]
- 1 GOLD PLATED REGION.

NOTES: UNLESS OTHERWISE SPECIFIED

TE INTERNAL PN	DEUTSCH PN	REV	PLATING
1060-16-0122	1060-16-0122	S	Ni/Cu overall, Sn/Ni/Cu Wire Barrel
1060-16-0144	1060-16-0144	S	Selective Au, Ni/Cu overall, Sn/Ni/Cu Wire Barrel
1060-16-0177	1060-16-0177	S	Sn/Ni/Cu overall

THIS DRAWING IS A CONTROLLED DOCUMENT.		DWN M. BLUM 04NOV1999	TE Connectivity	
DIMENSIONS: INCHES [mm]		CHK A. ROLINSKI 08DEC2000		
TOLERANCES UNLESS OTHERWISE SPECIFIED:		APVD R. REED 08DEC2000	PRODUCT SPEC 108-151000	RESTRICTED TO -
0 PLC ± 1 PLC ± 2 PLC ± 3 PLC ±.025 [0.64] 4 PLC ± ANGLES ±		APPLICATION SPEC 114-151000	SIZE A3	CAGE CODE 4AFU8
MATERIAL 3	FINISH SEE TABLE	WEIGHT 0.33 g	DRAWING NO C=1060-16-01XX	SCALE 6:1
Customer Drawing			SHEET 1 OF 1	REV L2

LOC	DIST	REVISIONS					
		P	LTR	DESCRIPTION	DATE	DWN	APVD
-	-		C	REVISED PER ECO-13-013634	8-26-13	RLM	DM
			CI	REVISED PER ECO-14-005288	4-9-14	PV	DM
			G	REVISED PER PCN-23-190134	29SEP2023	GB	CB
			GI	REVISED PER PCN-25-261461	05NOV2025	AJ	MB

OPTIONAL GATE VESTIGE
 APPROX. AS SHOWN

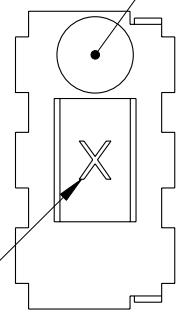

CAVITY I.D. APPROX.
 AS SHOWN.

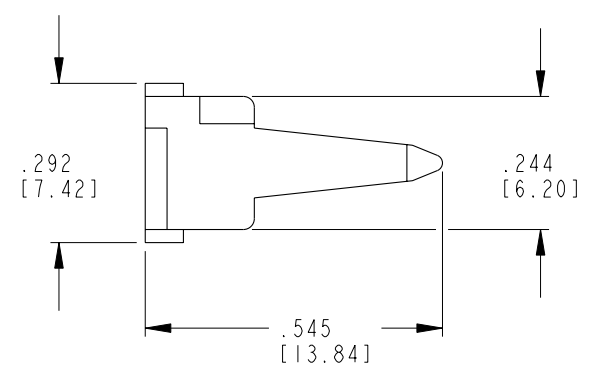
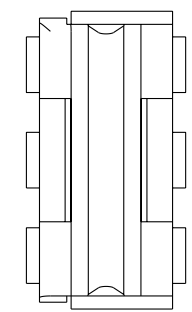
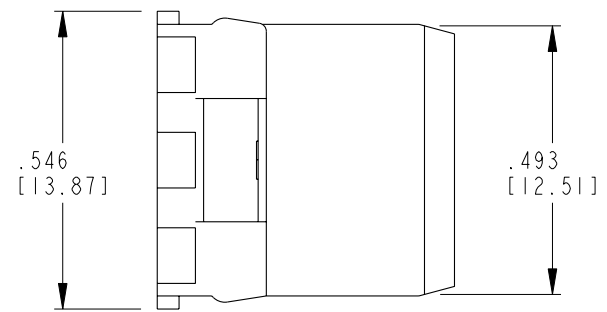
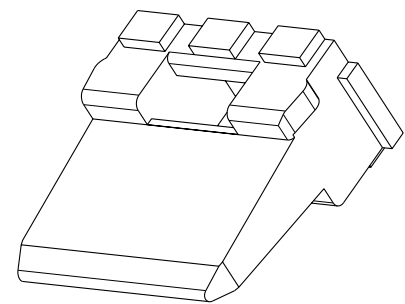

1. USED WITH DT04-6P-XXXX (XXXX = ALL MODIFICATIONS).
 CONSULT FACTORY FOR MODIFICATIONS AND APPLICATION.

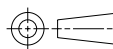
THIS DRAWING IS A CONTROLLED DOCUMENT.		DWN R. MESSENGER 16AUG2013	 TE Connectivity	
DIMENSIONS: INCHES [mm]		CHK R. MESSENGER 28MAR2014		
TOLERANCES UNLESS OTHERWISE SPECIFIED:		APVD D. MEYER 28MAR2014	NAME WEDGELock 6 WAY RECEPTACLE DT SERIES	
		PRODUCT SPEC 108-151009	RESTRICTED TO	
0 PLC ±. 1 PLC ±. 2 PLC ±. 3 PLC ±0.025 [0.64] 4 PLC ±. ANGLES ±0°30'0"		APPLICATION SPEC 114-151009	SIZE A3	CAGE CODE 4AFU8
MATERIAL PBT GF30 GREEN	FINISH -	WEIGHT 0.84 g	DRAWING NO C=W6P	
CUSTOMER DRAWING			SCALE 4:1	SHEET 1 OF 1 REV GI

