

M 626-C

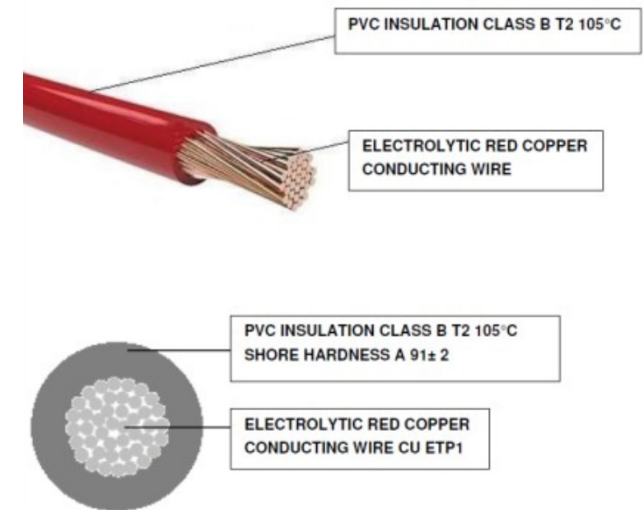

Caratteristiche CAVO	
Temperatura d'uso	-40 °C / +105 °C (IDLE STATE)
Sezione	1.00 mmq
Colore	Marrone
Documenti di riferimento	ISO 19642 : 2019 / DIN 72551 ISO 6722 CLASS B / LV 112 / ISO 3795 FIAT 91107 / 18 (where applicable) ROHS II/III UN R118
Lunghezza	20 cm
Tipologia	F3T2



CROSS SECTION	COND. CONSTR.	EXT. DIAMETER.	INSUL. MATERIAL	EL. RES. MAX 20°	MAX VOLT.	INSULATION THICKNESS (+)
1 x 1,00	32 x 0,20 ± 0,01 mm	2,10 +0 mm -0,2 mm	PVC T2 HT 105 °C	18,5 OHM/KM	< 300 V	≥ 0,24

Proseguire nella pagina successiva per visualizzare la scheda tecnica dei componenti

Revisione	Prodotto
REV.00 10/04/2026	OEM

SYMBOL DEFINITION		TOTAL NO OF INSPECTIONS REQUIRED	
A DIMENSION WITHOUT AN INSPECTION REPORT SYMBOL DOES NOT REQUIRE INSPECTION. IT MAY BE CONTROLLED ON THE INDIVIDUAL COMPONENT DRAWING.		10	
	LAST NO. USED	10	

MISSING SYMBOLS				REVISION HISTORY			
DATE	STG	REV	W/P	CHG	ZONE	REVISED BY	DATE
14JAO0	R	001	-	-		CLEARED REV COLUMN: ALL ACTIVE PARTS-UPDATED PDM ATTRIBUTES	196648 CRW/081 LLD
17JL00	R	002	-	-		REINSTATE 12077412	000010 JIB/JIB JA
150C04	R	03	-	-		ALL ACTIVE PARTS - ADDED TERMINAL ID NOTE	260003 RTV/JVM/MKM
24FE05	R	04	-	-		ALL ACTIVE PARTS - REVISED MAT'L SPEC & DRAWING NAME	265136 JS JS TM
18MY05	R	05	-	-		12176389 - UPDATED PDM ATTRIBUTES	268280 JBD/FKV WTM
30SE05	R	06	-	-		12077411, 12077413, 12084201, 12129493 & 12176389 - UPDATED PDM ATTRIBUTES; 12077411 - ADDED 1.0 MM² CABLE; ALL ACTIVE PARTS - ADDED NOTE# 6	272905 JTV/AUG WTM
11JAO8	R	07	-	-		ALL PARTS - 2X 5 +/-0.15 TYP WAS 2X 5 +/-0.01 TYP	403419 WHC/WHC WTM
18FE15	R	08	-	-		33231919 - RELEASED AND 12176387-90 - ADDED TARNISH NOTE	428904 NRM/JVM DS

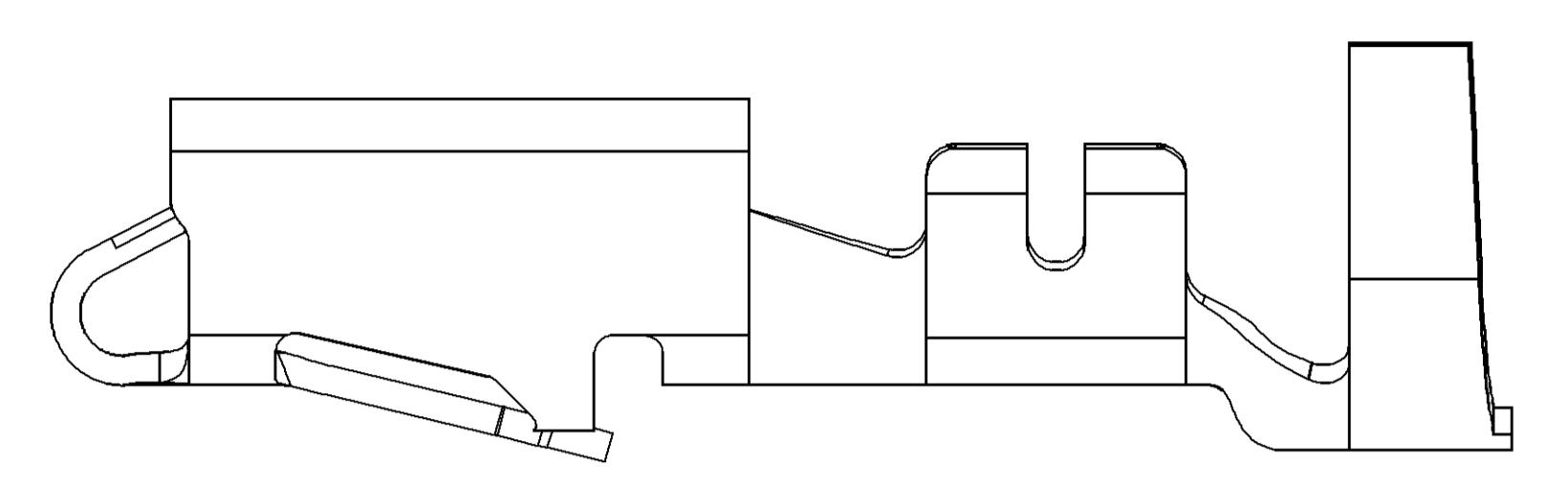

TYPE 102
SAME AS TYPE 101
EXCEPT AS SHOWN

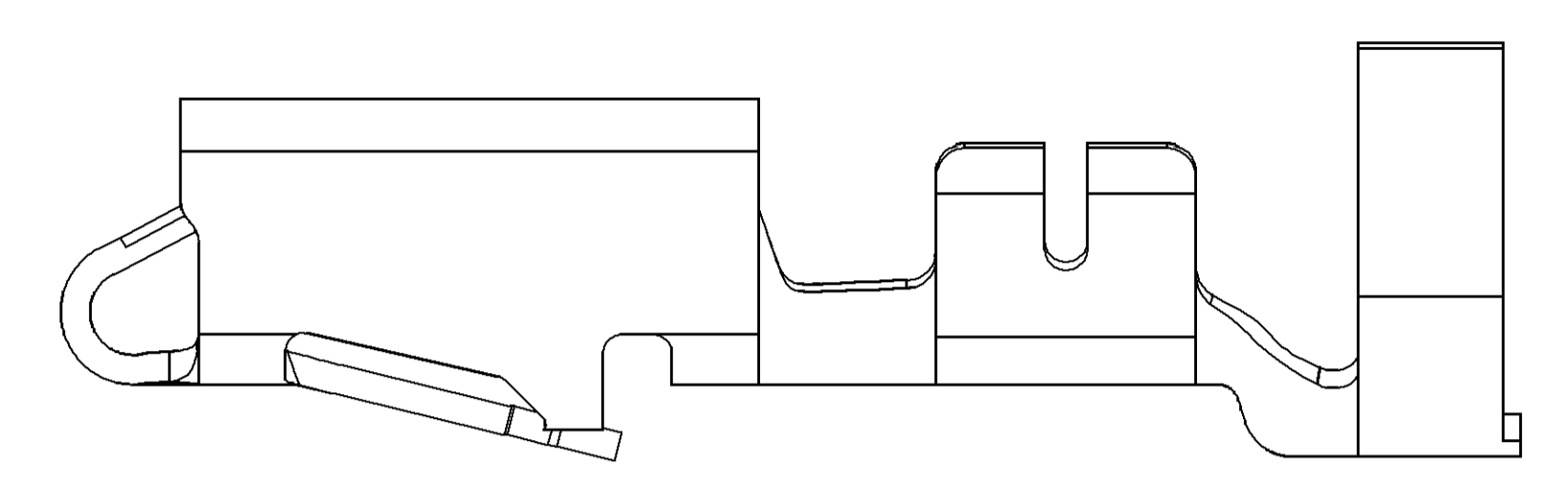

TYPE 103
SAME AS TYPE 101
EXCEPT AS SHOWN

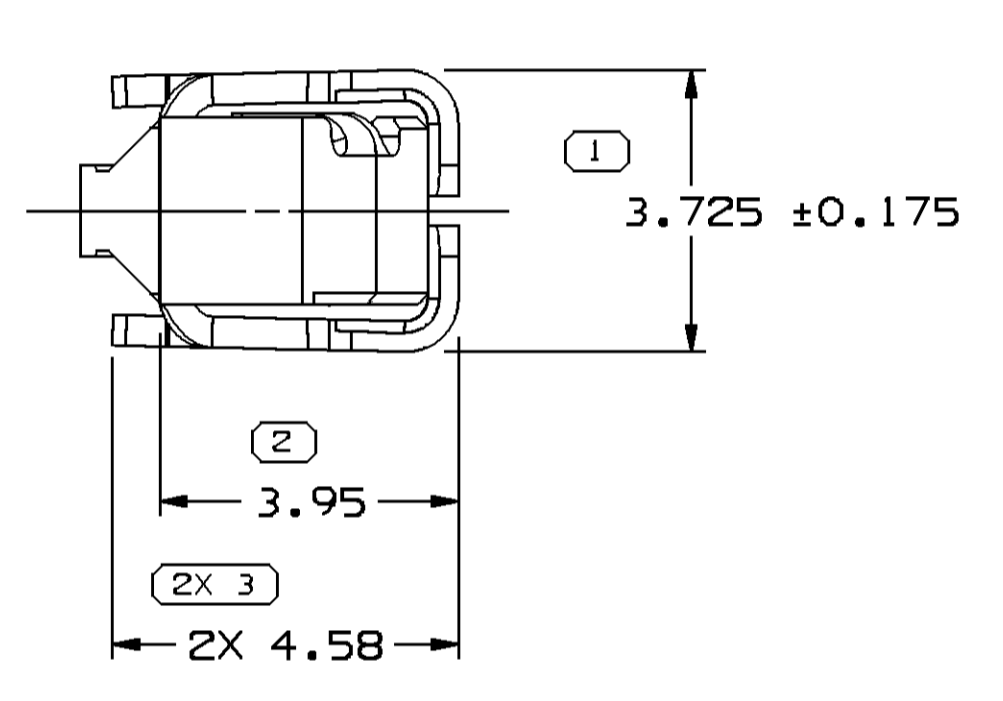
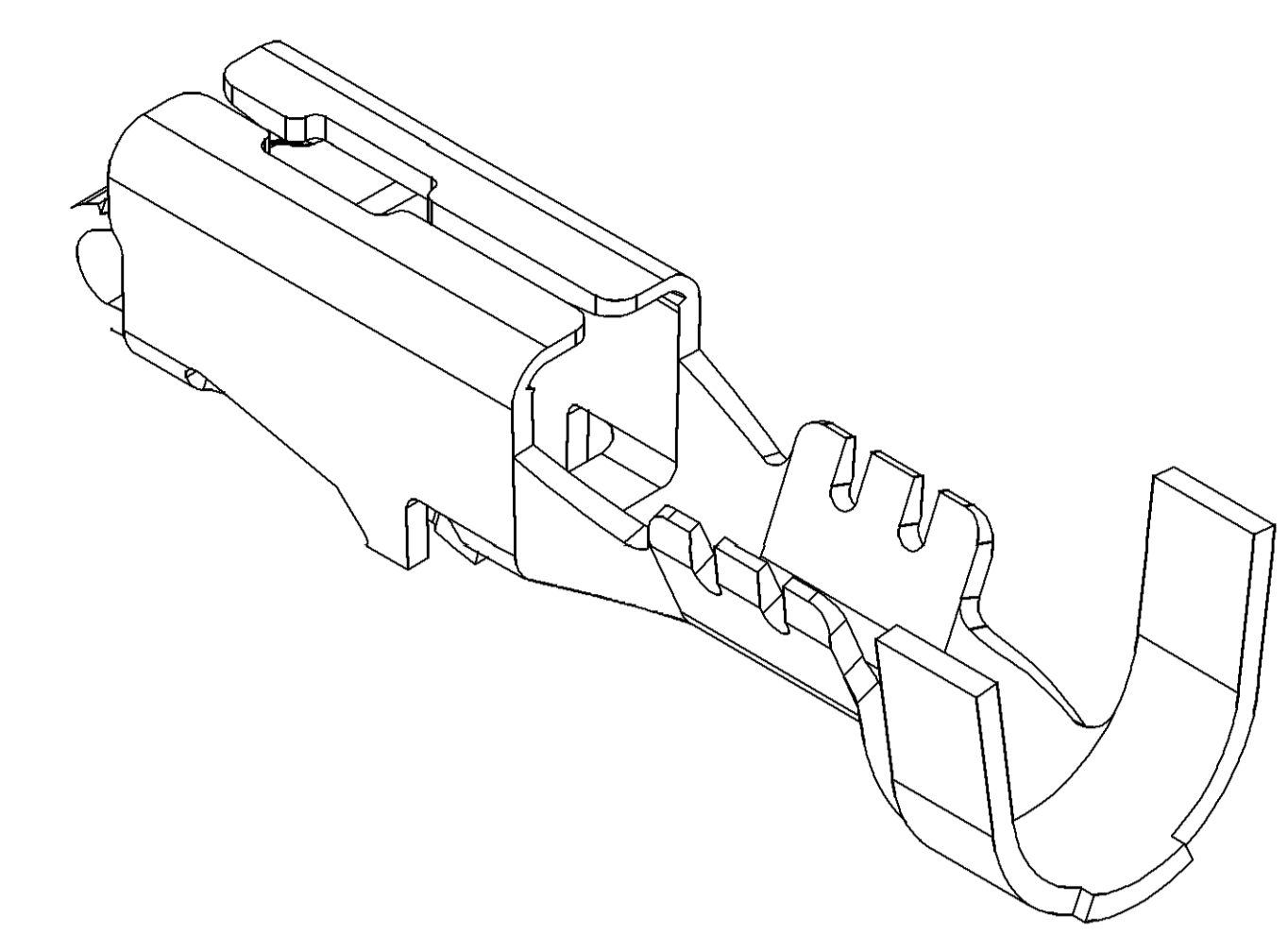

VIEW TO X-X

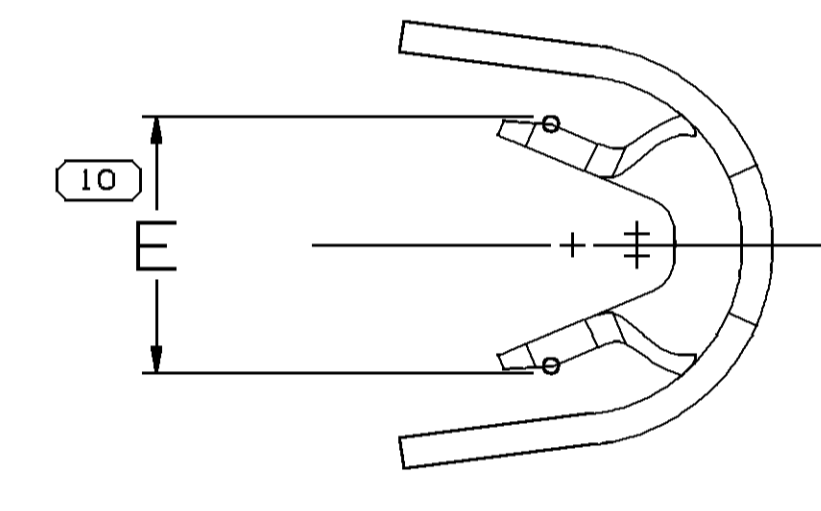
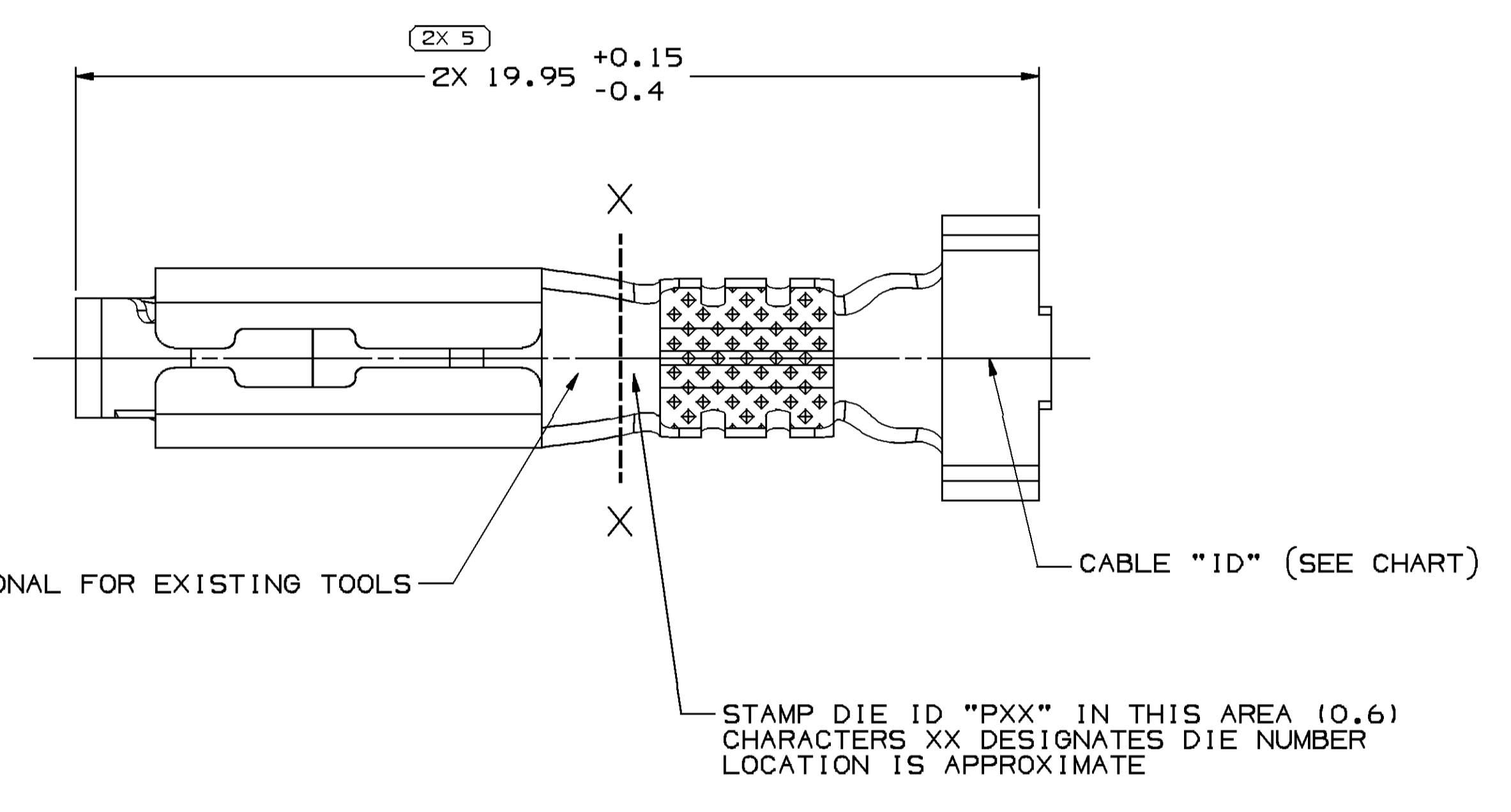

VIEW TO X-X

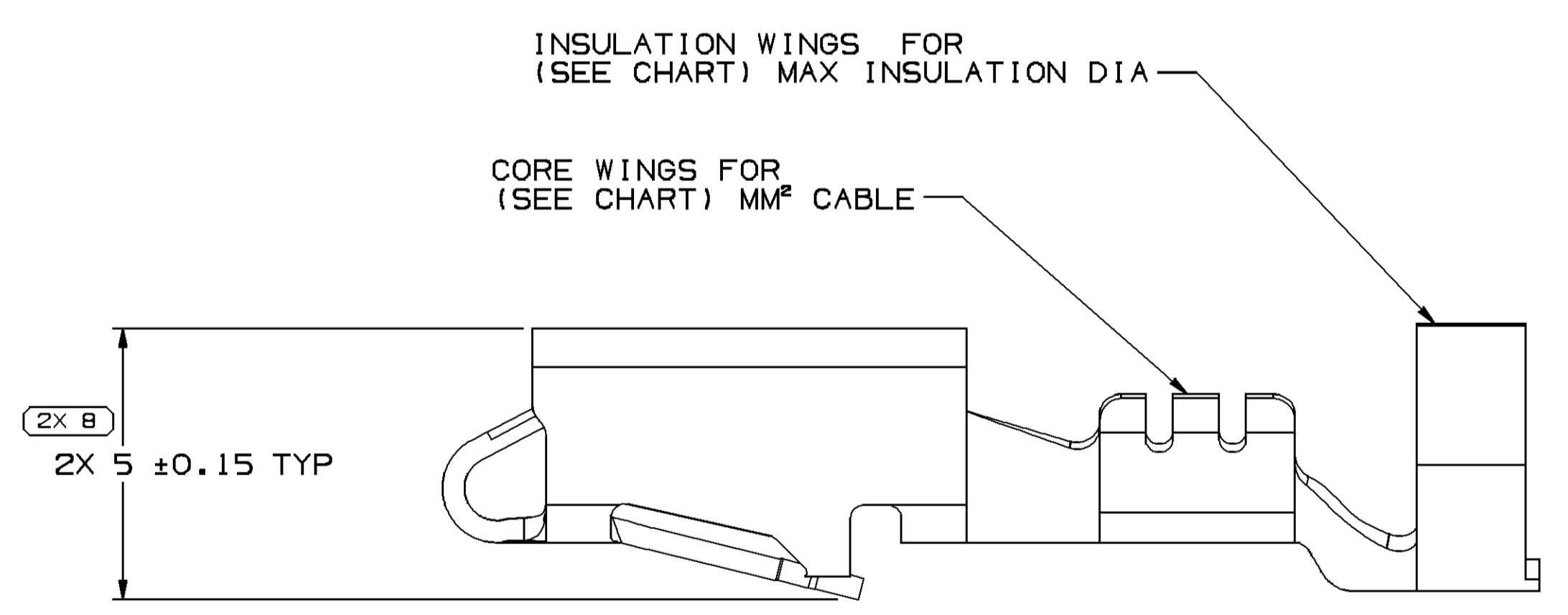

TYPE 101

- NOTES
- UNLESS OTHERWISE SPECIFIED AND/OR INDICATED: DIMENSIONS ARE TO FACE OF VIEW SHOWN AND AUTOMATICALLY ROUNDED BY COMPUTER FOR INSPECTION (SEE MATH MODEL FOR PRECISE DIMENSIONS). FOR ALL OTHER DIMENSIONS NOT SHOWN BUT REQUIRED FOR TOOL BUILD, SEE MATH MODEL FOR PRECISE TOOL PATH DATA.
 - R 0.4 PERMISSIBLE ON ALL "SHARP" CORNERS
 - RECOMMENDED MATING BLADE 2.8 X 0.81.
 - TERMINALS TO CRIMP AROUND AND RETAIN CAVITY SEAL 12015323 OR EQUIVALENT.
 - "PXX" INDICATES "P" PLUS LAST TWO DIGITS OF MAKE SERIES NUMBER (PO1, PO2, PO3, ETC.).
 - DO NOT PROBE, TEST OR OTHERWISE CONTACT THE INTERIOR REGION (THE SPRING OR ANY MOVING PART) OF THIS TERMINAL. SEVERE DAMAGE CAN OCCUR, COMPROMISING THE PERFORMANCE OF THE ELECTRICAL INTERFACE.
 - FOR TERMINALS PACKAGED & STORED IN THE APPROVED MANNER, TARNISH ON SILVER PLATED SURFACES WILL NOT AFFECT THE PERFORMANCE OF THE PART.

PART NO	REV	MAT'L SIZE	SPEC	PART NO	REV/N/P	MAT'L SPEC	SIZE (MM²)	CABLE	ID	TYPE	
-	-	0.406 X 30.56	-	12176390	AB	AG PLATED COPPER ALLOY	0.35-0.5	0.35-0.5	21	103	2.4±0.2
-	-	-	-	12176389	A9	AG PLATED COPPER ALLOY	0.8-1	2.03-3.12	19	101	3.2±0.4
-	-	0.406 X 30.56	-	33231919	O1	AG PLATED COPPER ALLOY	1-2	2.48-3.05	15	103	3.7±0.4
-	-	0.406 X 30.56	-	12176388	AB	AG PLATED COPPER ALLOY	2-3	2.45-3.80	13	103	4±0.4
-	-	0.406 X 30.56	-	12176387	AB	AG PLATED COPPER ALLOY	5	3.49-3.65	12	103	4.6±0.4
-	-	0.406 X 30.56	-	12129493	CB	TIN PLATED COPPER ALLOY	2-3	2.45-3.80	13	103	4±0.4
-	-	0.406 X 30.56	-	12084201	E11	TIN PLATED COPPER ALLOY	0.35-0.5	1.84-2.51	21	101	2.4±0.2
-	-	0.406 X 30.56	-	12077413	E11	TIN PLATED COPPER ALLOY	3	3.49-3.65	12	103	4.6±0.4
-	-	0.406 X 30.56	-	12077412	E9	TIN PLATED COPPER ALLOY	1-2	2.48-3.05	15	103	3.7±0.4
-	-	0.406 X 30.56	-	12077411	E11	TIN PLATED COPPER ALLOY	0.5-0.8-1.0	2.03-3.12	19	101	3.2±0.4
-	-	0.406 X 32.54	-	12045639	DB	P1519027 425 TIN BRS EX HD SN PLTD	3	3.49-3.65	12	102	4.6±0.4
-	-	0.406 X 32.54	-	12034454	FB	P1519027 425 TIN BRS EX HD SN PLTD	1-2	2.48-3.05	15	102	3.7±0.4
-	-	0.406 X 32.54	-	12026648	HB	P1519027 425 TIN BRS EX HD SN PLTD	0.5-0.8	2.03-3.12	19	101	3.2±0.4
PART NO	REV	MAT'L SIZE	SPEC	PART NO	REV/N/P	MAT'L SPEC	SIZE (MM²)	CABLE	ID	TYPE	
-	-	UNPLATED	-	-	-	-	-	-	-	-	

DELPHI
DELPHI PACKARD ELECTRICAL/ELECTRONIC ARCHITECTURE
WARREN, OH
COPYRIGHT 1998 DELPHI CORPORATION AND/OR ITS AFFILIATES. ALL RIGHTS RESERVED.
THIS DRAWING IS THE PROPERTY OF DELPHI CORPORATION AND CONTAINS DELPHI CONFIDENTIAL INFORMATION. THE REPRODUCTION, DISTRIBUTION AND UTILIZATION OF THIS DOCUMENT OR ITS CONTENTS OR DATA, AS WELL AS COMMUNICATION OF ANY CONTENT TO OTHERS, WITHOUT EXPRESS AUTHORIZATION, IS PROHIBITED.

DATE: 16JUL98

OR: JORGE IBARRA, OSCAR OCHOA, O. GALLEGOS

THIS DOCUMENT IS IN ACCORDANCE WITH ASME Y14.5M-1994 AS MODIFIED BY THE 1995 SUPPLEMENT AND TELEPHONING ADDENDUM-2001. SEPARATE PATTERNS OF FEATURES MAY BE SHOWN SEPARATELY, REGARDLESS OF DATUM REFERENCES.

UNLESS OTHERWISE SPECIFIED

ALL DIMENSIONS ARE IN MILLIMETERS

REFERENCE: UNLESS OTHERWISE SPECIFIED

THIRD ANGLE PROJECTION

DO NOT SCALE

USE MATH DATA

DRAWING NUMBER: 12089195

TAXI TERM F/M/P 280 SEALED

SIZE: A0, SCALE: 10:1, FRAME NO: 1 OF 1, SHEET NO: 1 OF 1, STG: R, REV: 08

Date: 05-Nov-15 Time: 11:14

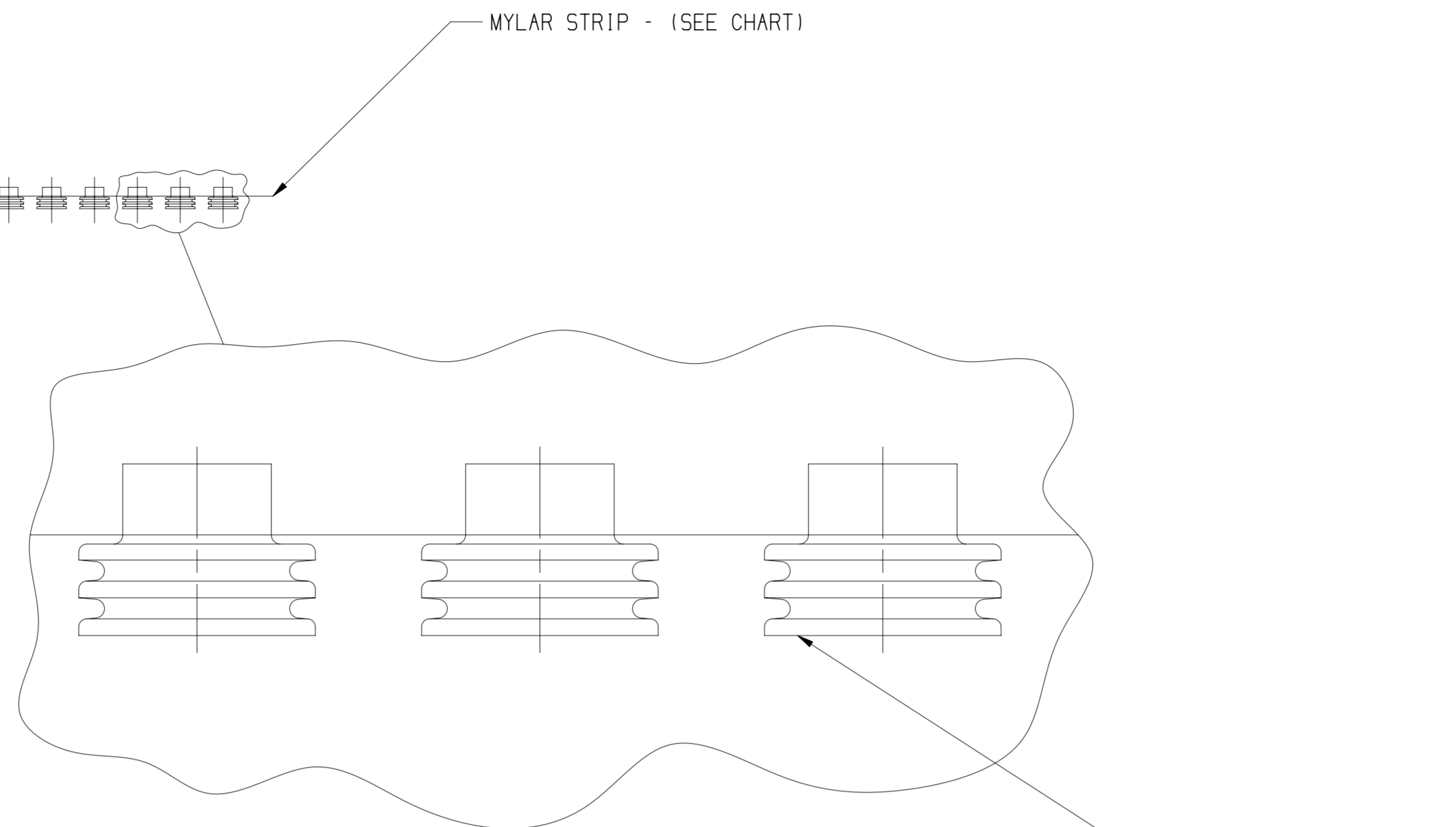
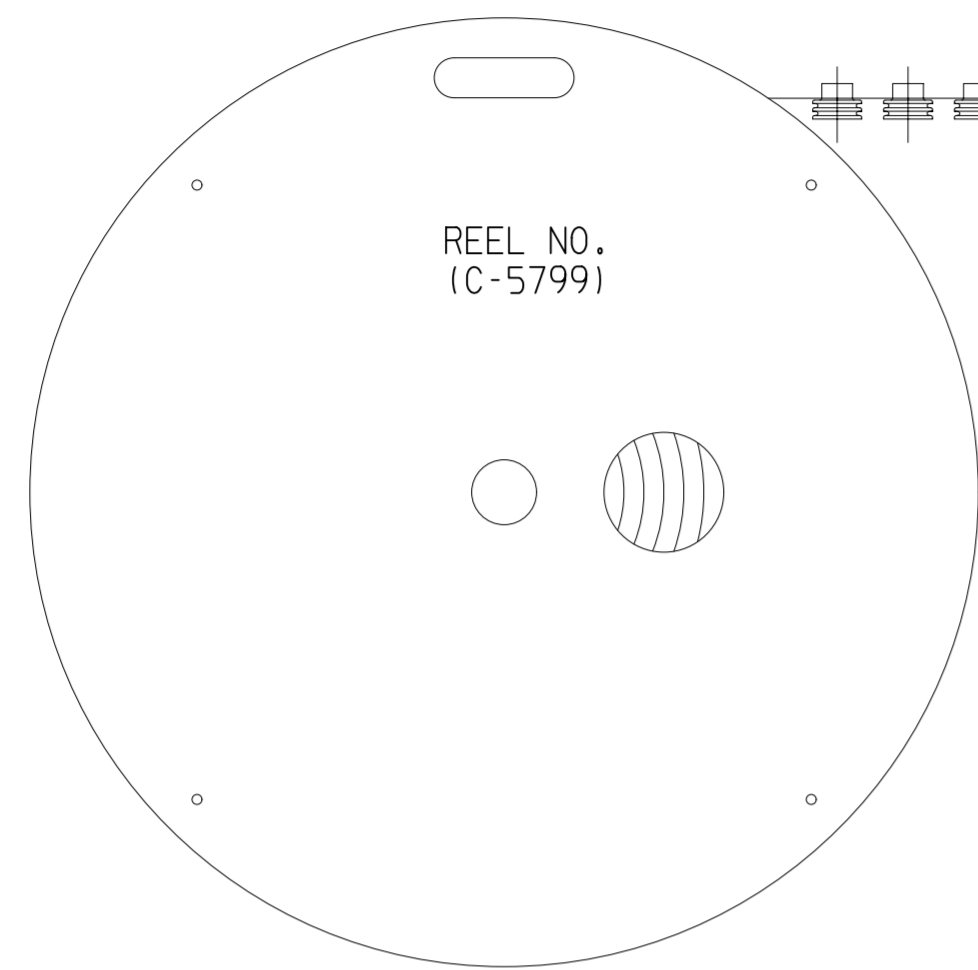

SEAL/MYLAR ASSEMBLY DETAIL

DWG STATUS					ZONE	REVISION HISTORY	AUTH	DR	APVD1	APVD2
DATE	STG	REV	N/P	CHG						
040C95	R	-	-	-		12186526 RELEASED TO REV "A"	950005	CTC	CTC	FKV
31AU96	R	-	-	-		12186809 RELEASED TO REV "A"	960005	MVA	MVA	MVA
26N096	R	-	-	-		12186914 & 12186915 - RELEASED TO REV "A"	960005	J6S	J6S	J6S
02JL97	R	-	-	-		REVISION COLUMN CLEARED, 15324059 RELEASED TO REV "A"	970005	HH	HH	J1B
19N097	R	-	-	-		NO REV UPDATE REQ'D	182650	AD	GMC	GMC
16JN98	R	-	-	-		16186914 & 16186915 - OBSOLETE	980003	RGT	RCH	RCH
01MR10	R	01	-	-		ALL ACTIVE PARTS - REDRAWN TO PD; 12186809 - CABLE SEAL WAS 12186701	410105	MAL	MAL	MPR
15JN10	R	02	-	-		12015284, 12015359-60, 12034365, 12041352 & 12089444 - WERE ON SHT 01 AND UPDATED SEAL; 10717640, 12146012, 15338470, 15363980, 91, 15497746, 55 & 57 - WERE ON SHT 01; 12048433, 12052452-53 & 12052931 - WERE ON SHT 02 AND UPDATED SEAL; 12065703, 12124843 & 12162068 - WERE ON SHT 02; 12059258-60 - WERE ON SHT 03 AND UPDATED SEAL; 10730240-41, 12059257, 59, 12077760, 15344032 & 15344951 - WERE ON SHT 03; 12052924-25 & 12089442 - WERE ON SHT 04 AND UPDATED SEAL; 12124669, 12146011, 12186770 & 13713910 - WERE ON SHT 04	411067	AGM	JAA	MPR
08MR12	R	03	-	-		MYLAR SPEC ADDED ON PD, AND REEL WAS REFERENCED.	417411	EGH	EGH	EGH
19MR12	R	04	-	-		13713910, 12186770, 12162068, 12146011, 12124843, 12124669, 12089442, 12077760, 12065703, 12059260, 12059259, 12059258, 12059257, 12052931, 12052925, 12052924, 12052453, 12052452, 12048433, 15324059, 12186914, 12186809, 12186526, RELEASE PROPERTIES OF COLOR	417542	EGH	EGH	EGH
24MR12	R	05	-	-		UPDATE 12059258 NON PHYSICAL CHANGE	417674	EGH	EGH	EGH
09AU23	R	06	-	-		12034365, 15363991, 15338470, 15363980, 10717640, 15344032, 10730241 & 15344951 - OBSOLETE AND ADDED REPLACED BY INFO	561315	GDH	ORA	CA

15344951	01	AC	15324995	M5235005	MATERIAL CARRIER STRIP CBL SEAL	15324995
10730241	01	AC	15324994	M5235005	MATERIAL CARRIER STRIP CBL SEAL	15324994
15344032	01	AC	15324996	M5235005	MATERIAL CARRIER STRIP CBL SEAL	15324996
10730240	03	AB	15324997	M5235005	MATERIAL CARRIER STRIP CBL SEAL	-
15363991	01	AC	15324980	M5235003	MATERIAL CARRIER STRIP CBL SEAL	15324980
10717640	01	AC	15324981	M5235003	MATERIAL CARRIER STRIP CBL SEAL	15324981
15363980	01	AC	15324982	M5235003	MATERIAL CARRIER STRIP CBL SEAL	15324982
15338470	02	AC	15324985	M5235003	MATERIAL CARRIER STRIP CBL SEAL	15324985
15497757	01	AD	15497756	M5235003	MATERIAL CARRIER STRIP CBL SEAL	-
15497755	01	AD	15497754	M5235003	MATERIAL CARRIER STRIP CBL SEAL	-
15497746	01	AD	15497745	M5235003	MATERIAL CARRIER STRIP CBL SEAL	-
13713910	01	AA	13713911	M5235004	MATERIAL CARRIER STRIP CBL SEAL	-
12186770	B5	-	12186769	M5235004	MATERIAL CARRIER STRIP CBL SEAL	-
12162068	A6	-	12162067	M5235005	MATERIAL CARRIER STRIP CBL SEAL	-
12146012	A1	-	12129930	M5235003	MATERIAL CARRIER STRIP CBL SEAL	-
12146011	A	-	12129926	M5235004	MATERIAL CARRIER STRIP CBL SEAL	-
12124843	A1	-	12110210	M5235005	MATERIAL CARRIER STRIP CBL SEAL	-
12124669	A5	-	12084193	M5235004	MATERIAL CARRIER STRIP CBL SEAL	-
12089444	03	-	15324985	M5235003	MATERIAL CARRIER STRIP CBL SEAL	-
12089442	03	AA	15324976	M5235004	MATERIAL CARRIER STRIP CBL SEAL	-
12077760	A4	-	12077759	M5235005	MATERIAL CARRIER STRIP CBL SEAL	-
12065703	A6	-	12034170	M5235005	MATERIAL CARRIER STRIP CBL SEAL	-
12059260	02	AA	15324996	M5235005	MATERIAL CARRIER STRIP CBL SEAL	-
12059259	A4	-	12052388	M5235005	MATERIAL CARRIER STRIP CBL SEAL	-
12059258	02	AC	15324994	M5235005	MATERIAL CARRIER STRIP CBL SEAL	-
12059257	A4	-	12052386	M5235005	MATERIAL CARRIER STRIP CBL SEAL	-
12052931	02	AA	15324991	M5235005	MATERIAL CARRIER STRIP CBL SEAL	-
12052925	02	AA	15324974	M5235004	MATERIAL CARRIER STRIP CBL SEAL	-
12052924	02	AA	15324973	M5235004	MATERIAL CARRIER STRIP CBL SEAL	-
12052453	02	AA	15324990	M5235005	MATERIAL CARRIER STRIP CBL SEAL	-
12052452	02	AA	15324989	M5235005	MATERIAL CARRIER STRIP CBL SEAL	-
12048433	02	AA	15324988	M5235005	MATERIAL CARRIER STRIP CBL SEAL	-
12041352	02	-	15324984	M5235003	MATERIAL CARRIER STRIP CBL SEAL	-
12034365	02	AA	15324983	M5235003	MATERIAL CARRIER STRIP CBL SEAL	15324983
12015360	02	-	15324981	M5235003	MATERIAL CARRIER STRIP CBL SEAL	-
12015359	02	-	15324980	M5235003	MATERIAL CARRIER STRIP CBL SEAL	-
12015284	02	-	15324982	M5235003	MATERIAL CARRIER STRIP CBL SEAL	-
15324059	A1	-	12047516	M5235004	MATERIAL CARRIER STRIP CBL SEAL	-
12186915	A	-	12162965	M5235001	MATERIAL CARRIER STRIP CBL SEAL	-
12186914	A	-	12186004	M5235004	MATERIAL CARRIER STRIP CBL SEAL	-
12186809	A2	-	10737670	M5235004	MATERIAL CARRIER STRIP CBL SEAL	-
12186526	A1	-	12162575	M5235004	MATERIAL CARRIER STRIP CBL SEAL	-
PART NO	REV	N/P	PART NO			REPLACED BY
MYLAR & CABLE SEAL ASM			CABLE SEAL		MYLAR SPEC	

NOTES

- UNLESS OTHERWISE SPECIFIED AND/OR INDICATED:
DIMENSIONS ARE TO FACE OF VIEW SHOWN AND AUTOMATICALLY ROUNDED BY COMPUTER FOR INSPECTION (SEE MATH MODEL FOR PRECISE DIMENSIONS). FOR ALL OTHER DIMENSIONS NOT SHOWN BUT REQUIRED FOR TOOL BUILD, SEE MATH MODEL FOR PRECISE TOOL PATH DATA.
- THE MYLAR TAPE IS ONLY A CARRIER USED AS A PROCESS AID AND IS NOT PART OF THE FINAL HARNESS ASSEMBLY.
- THIS PRODUCT IS NOT CATEGORIZED AS AN APPEARANCE ITEM, MINOR IMPERFECTIONS INCLUDING, BUT NOT LIMITED TO, FLOW MARKS, COLOR BLEMISHES, GATE VESTIGE, AND SOFT FLASH THAT DO NOT AFFECT THE FIT, FORM, OR FUNCTION OF THE PART ARE PERMISSIBLE PER EANP-4-3_CS-01-EN.

(N/A) PROCESS SENSITIVE DIMENSION
DIMENSIONS ENCLOSED IN () INDICATE REFERENCE DIMENSIONS AND NO TOLERANCE LIMITS ARE ESTABLISHED

DIMENSIONAL RANGE (MM)		CHART E1	
FROM	TO	> 20	> 300
> 0	> 20	> 30	> 100
> 20	> 30	> 70	> 150
> 30	> 70	> 100	> 200
> 70	> 100	> 150	> 250
> 100	> 150	> 200	> 300
> 150	> 200	> 250	> 400
TOLERANCE UNLESS OTHERWISE SPECIFIED			
±0.15	±0.2	±0.3	±0.4
±0.5	±0.6	±0.8	±1
ANGULAR TOLERANCE ±2°			

A LINE DRAWN THROUGH A PART NUMBER INDICATES THAT PHYSICAL PARTS ARE NOT AVAILABLE FOR ORDERING.

PART NUMBERS THAT DO NOT HAVE A LINE PRESENT INDICATE THAT PHYSICAL PARTS ARE AVAILABLE FOR ORDERING.

CONTACT APTIV SALES TO ASSURE AVAILABILITY OF PARTS.

DWG TYPE: PART DRAWING

STYLE: [Symbol]

VOLUME (CM³): [Symbol] DISTR CODE: [Symbol]

UNLESS OTHERWISE SPECIFIED THIS DOCUMENT IS IN ACCORDANCE WITH ASME Y14.5M-1994 AS AMENDED BY THE GM GLOBAL DIMENSIONING AND TOLERANCING ADDENDUM-2001. SEPARATE PATTERNS OF FEATURES MAY BE GAGED SEPARATELY REGARDLESS OF DATUM REFERENCES.

ALL DIMENSIONS ARE IN MILLIMETERS

REFERENCE: [Symbol]

THIRD ANGLE PROJECTION [Symbol]

DO NOT SCALE [Symbol]

USE MATH DATA [Symbol]

• APTIV •

CONNECTION SYSTEMS
WARREN, OH
COPYRIGHT 1989 APTIV. ALL RIGHTS RESERVED.

THIS DRAWING IS THE PROPERTY OF APTIV AND CONTAINS APTIV CONFIDENTIAL INFORMATION. THE REPRODUCTION, DISTRIBUTION AND UTILIZATION OF THIS DOCUMENT OR ITS RELATED CAD MATH DATA, AS WELL AS COMMUNICATION OF ANY CONTENT TO OTHERS, WITHOUT EXPRESS AUTHORIZATION, IS PROHIBITED.

DR	DATE
APVD1 J. HOUGELMAN	13JA89
APVD2 T. MUDREY	26JA89
APVD3 A. HERMANN	31JA89
APVD4	
APVD5	

SUBSTANCES OF CONCERN AND RECYCLED CONTENT PER APTIV 10949001

MATERIAL SEE CHART

DRAWING NAME: TAXI SEAL CBL 1W M/P

DRAWING NUMBER: 12010295

SIZE	SCALE	FRAME NO	SHEET NO	STG	REV	N/P
A1	10:1	1 OF 1	6 OF 6	R	06	-