

# M 628-K



**MINIKIT**

*Proseguire nella pagina successiva per visualizzare la scheda tecnica dei componenti*

Revisione	Prodotto
REV.00 10/04/2026	OEM

SYMBOL DEFINITION		MISSING NUMBERS		DWG STATUS				REVISION HISTORY				AUTH	DR	APVD	APVD		
THE NUMBER INSIDE THE SYMBOL CORRESPONDS TO THE NUMBER ON THE INSPECTION REPORT FOR THIS DRAWING/PART NUMBER	TOTAL NO. OF SYMBOLS ON DRAWING	LAST NO. USED		DATE	STG	REV	N/P	CHK	ZONE								
	8	10		22MY00	R	01	-	-		ALL PARTS - REDRAWN TO PD FORMAT: 12048369 MAT'L SPEC WAS R0065644 BLUE, 12129377 MAT'L SPEC WAS R0064366 MD GRV				199739	RH	GMC	JA
				19AP05	R	02	-	-		2X (13) TYP WAS 2X 13 TYP				267465	JBD	JAA	NTM

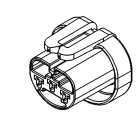
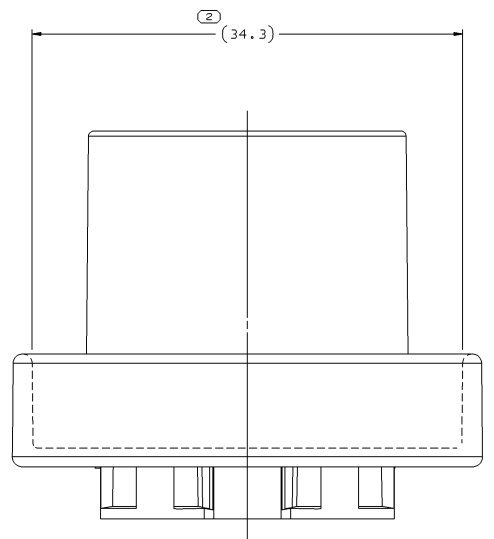
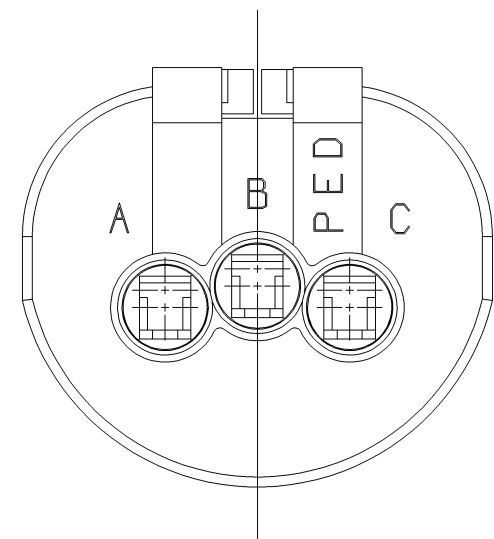
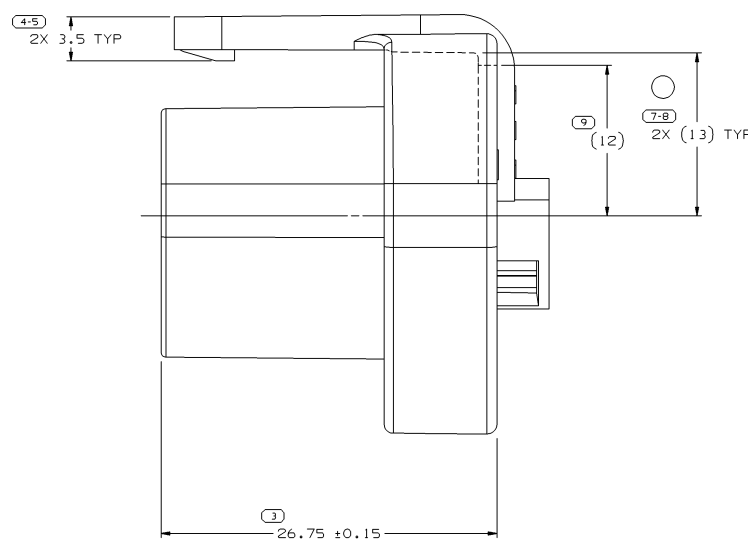
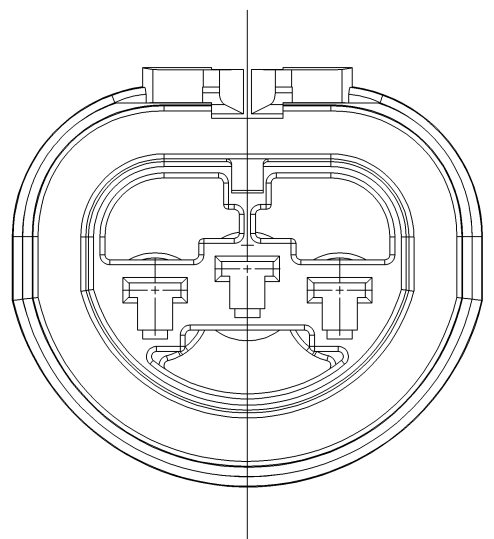
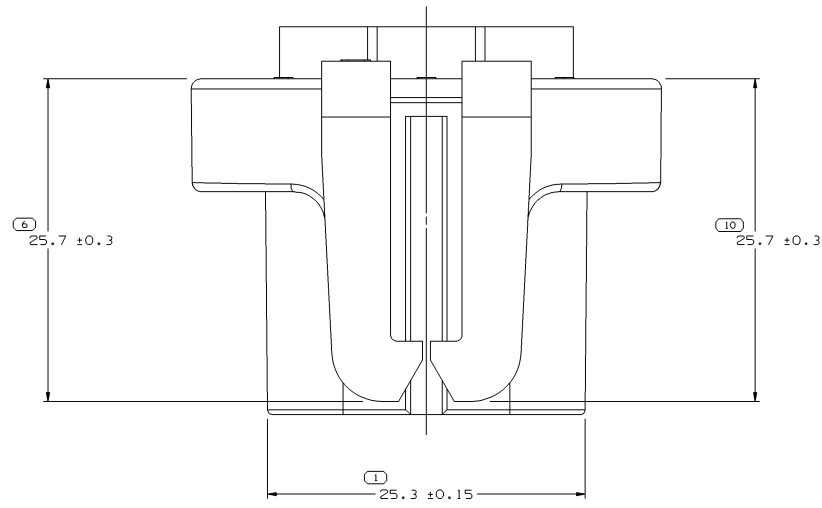

- NOTES**
- UNLESS OTHERWISE SPECIFIED AND/OR INDICATED:  
DIMENSIONS ARE TO FACE OF VIEW SHOWN AND AUTOMATICALLY ROUNDED BY COMPUTER FOR INSPECTION (SEE MATH MODEL FOR PRECISE DIMENSIONS). FOR ALL OTHER DIMENSIONS NOT SHOWN BUT REQUIRED FOR TOOL BUILD, SEE MATH MODEL FOR PRECISE TOOL PATH DATA.
  - REFERENCE MATING COMPONENTS OR EQUIVALENT:  
GM PART NO. 16504049 HEADLAMP BULB (TRADE NO. 9004)
  - THIS PART ACCEPTS THE FOLLOWING COMPONENTS OR EQUIVALENT:  
CAVITIES TO ACCEPT 12077411 TERMINAL OR EQUIVALENT.  
CABLE SEAL 12010295  
GASKET 12048370  
TERMINAL POSITION ASSURANCE LOCK 12048371
  - SEE CABLE SEAL AND T.P.A. DRAWINGS FOR COMPATIBLE CABLE O.D. RANGE.
  - THIS PART IS NOT CONTROLLED FOR AUTOMATIC FEEDING.
  - (2.3)X(0.1) DELPHI CORPORATE BRAND TO BE LOCATED ON ANY EXTERIOR SURFACE, PREFERABLY VISIBLE AT FINAL ASSEMBLY. OPTIONAL CONSTRUCTION FOR EXISTING TOOLING MAY BE "PED".

PART NO	REV	N/P	STATUS	MATERIAL SPECIFICATION AND COLOR	VOL CM <sup>3</sup>
12129377	02	AA	-	M3592025 PA66 HS IM GRA MD	8.138
12048369	06	AA	-	M3592008 PA66 HS IM BLU	8.138

DIMENSIONAL RANGE (MM)	TOLERANCE (UNLESS OTHERWISE SPECIFIED)	CHART REF
FROM > 0	> 20	> 30
TO > 20	> 30	> 70
	> 70	> 100
	> 100	> 150
	> 150	> 200
	> 200	> 250
	> 250	> 300
	> 300	> 400
	> 400	

DWG TYPE PART DRAWING	
STYLE	DISTR CODE
VOLUME (0/1) SEE CHART	D
UNLESS OTHERWISE SPECIFIED PERFECT FORM REQUIRED FOR FEATURES OF SIZE AT MIC. TRUE POSITION TOLERANCES AND RELATED DATUMS APPLY AT CONDITION OF SIZE INDICATED IN FEATURE CONTROL FRAME. ALL OTHER GEOMETRIC TOLERANCES AND RELATED DATUMS APPLY SFS. SEPARATE TRUE POSITION CALLOUTS MAY BE USED SEPARATELY, REGARDLESS OF DATUM REFERENCE. ALL DIMENSIONS ARE IN MILLIMETERS	
REFERENCE	THIRD ANGLE PROJECTION
DO NOT SCALE USE MATH DATA	UNSPRINTS

**DELPHI**  
DELPHI PACKARD ELECTRIC SYSTEMS  
WARREN, OH

DR	DATE
APVD1 R. HERMOSILLO	22MY00
APVD2 G. MACIAS	12JN00
APVD3 J. ALVAREZ	16JN00
APVD4	
APVD5	SUBSTANCES OF CONCERN AND RECYCLED CONTENT PER DELPHI 10949001

MATERIAL SEC. CHART

DRAWING NAME  
TAXI CONN 2 F M/P 280 SLD

DRAWING NUMBER  
12052373

SIZE	SCALE	FRAME NO	SHEET NO	STG	REV	N/P
A0	5:1	1 OF 1	3 OF 3	R	02	-

SYMBOL DEFINITION		TOTAL NO OF INSPECTIONS REQUIRED	
A DIMENSION WITHOUT AN INSPECTION REPORT SYMBOL DOES NOT REQUIRE INSPECTION. IT MAY BE CONTROLLED ON THE INDIVIDUAL COMPONENT DRAWING.		10	
	LAST NO. USED	10	

DWG STATUS				REVISION HISTORY				AUTH		DR		APVD	
DATE	STG	REV	W/P	CHG	ZONE	DESCRIPTION	DATE	BY	DATE	BY	DATE	BY	
14JAO0	R	001	-	-		CLEARED REV COLUMN: ALL ACTIVE PARTS-UPDATED PDM ATTRIBUTES	196648	CRW	081	LLD			
17JL00	R	002	-	-		REINSTATE 12077412	000010	JIB	JIB	JA			
150C04	R	03	-	-		ALL ACTIVE PARTS - ADDED TERMINAL ID NOTE	260003	RTV	JVM	MKM			
24FE05	R	04	-	-		ALL ACTIVE PARTS - REVISED MAT'L SPEC & DRAWING NAME	265136	JS	JS	TM			
18MY05	R	05	-	-		12176389 - UPDATED PDM ATTRIBUTES	268280	JBD	FKV	WTM			
30SE05	R	06	-	-		12077411, 12077413, 12084201, 12129493 & 12176389 - UPDATED PDM ATTRIBUTES; 12077411 - ADDED 1.0 MM² CABLE; ALL ACTIVE PARTS - ADDED NOTE# 6	272905	JTV	AUG	WTM			
11JAO8	R	07	-	-		ALL PARTS - 2X 5 +/-0.15 TYP WAS 2X 5 +/-0.01 TYP	403419	WHC	WHC	WTM			
18FE15	R	08	-	-		33231919 - RELEASED AND 12176387-90 - ADDED TARNISH NOTE	428904	NRM	JVM	DS			

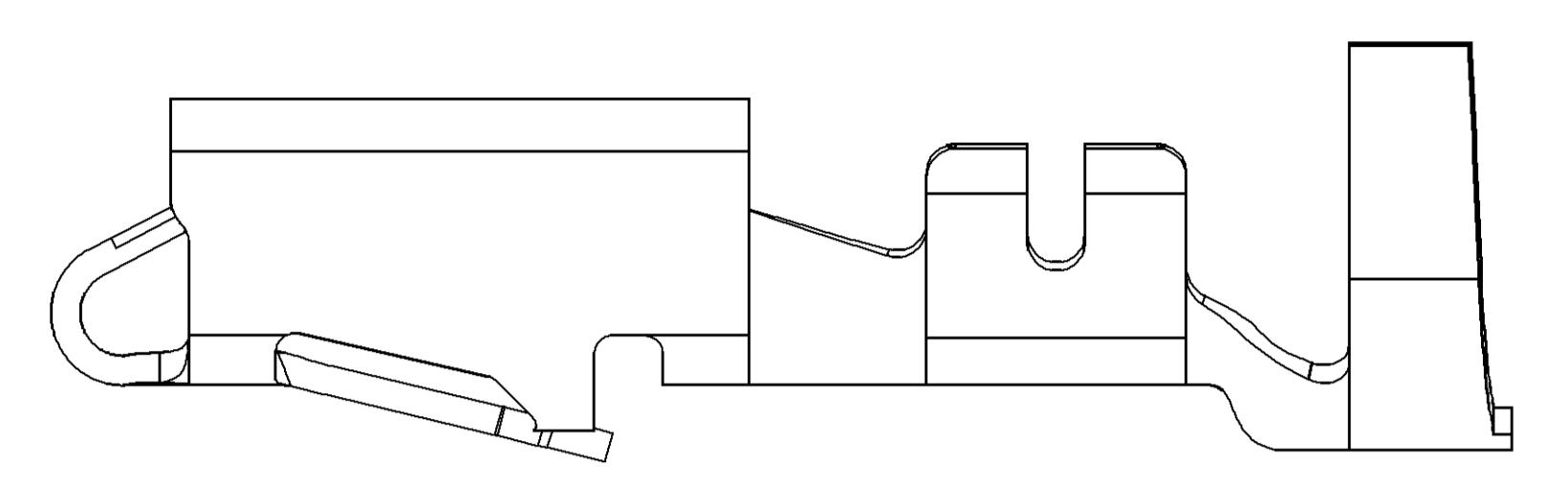

TYPE 102  
SAME AS TYPE 101  
EXCEPT AS SHOWN

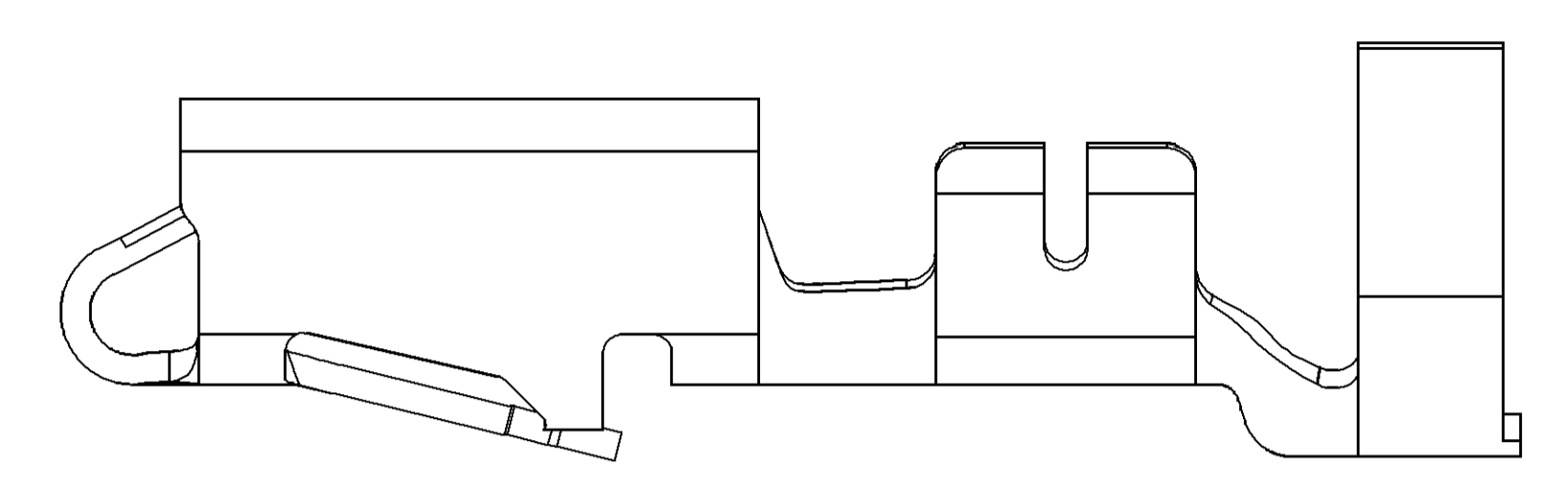

TYPE 103  
SAME AS TYPE 101  
EXCEPT AS SHOWN

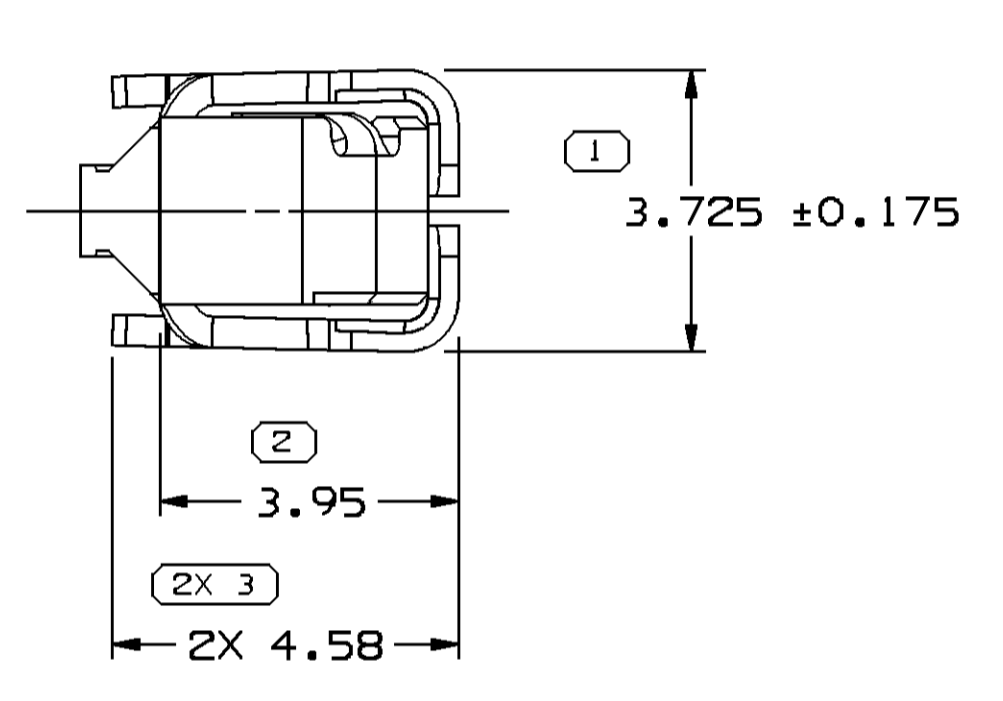
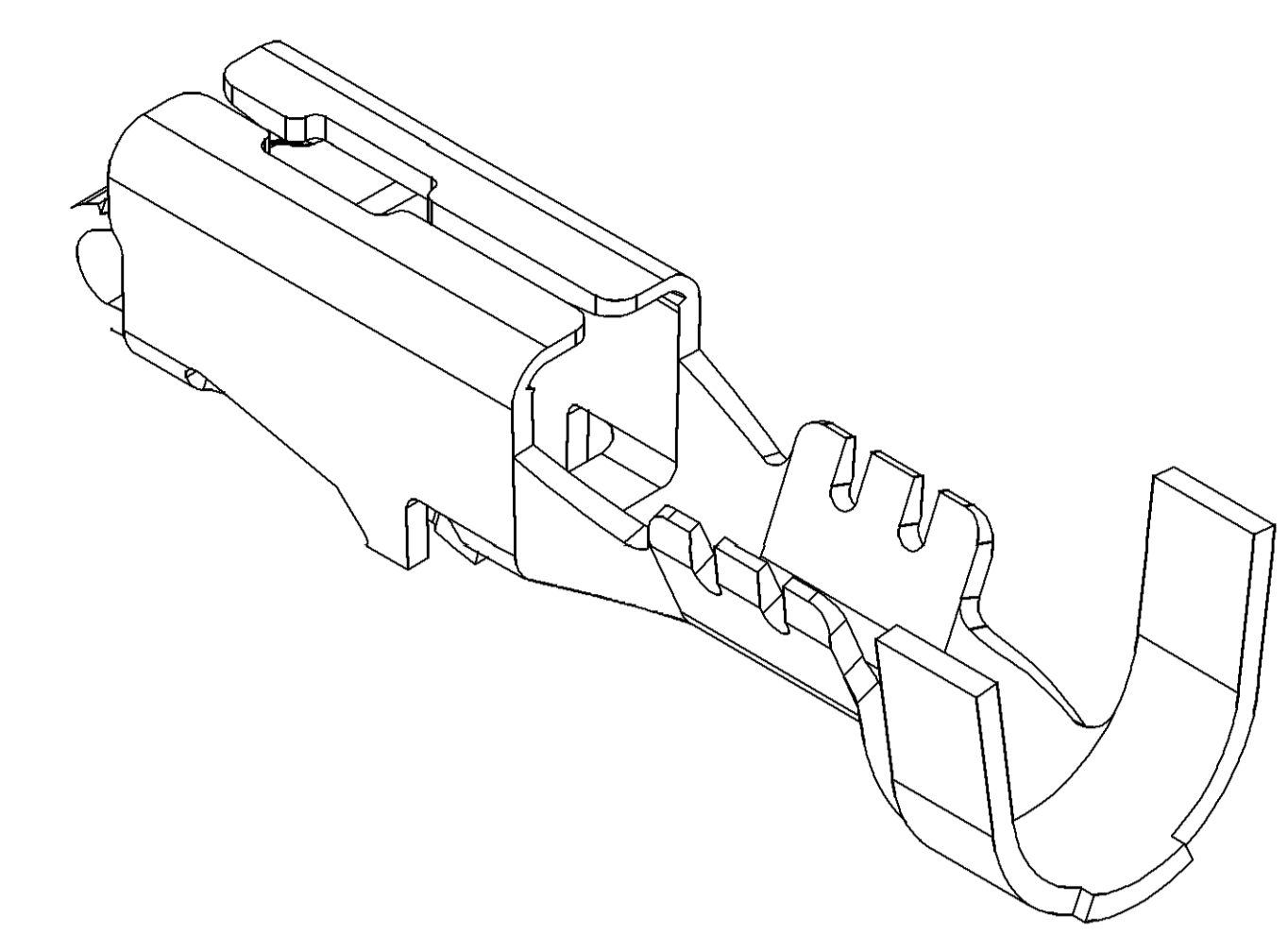

VIEW TO X-X

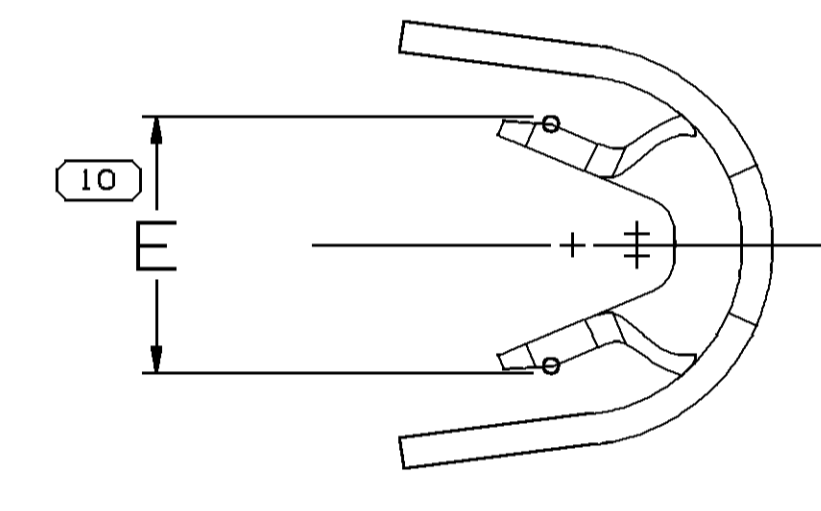
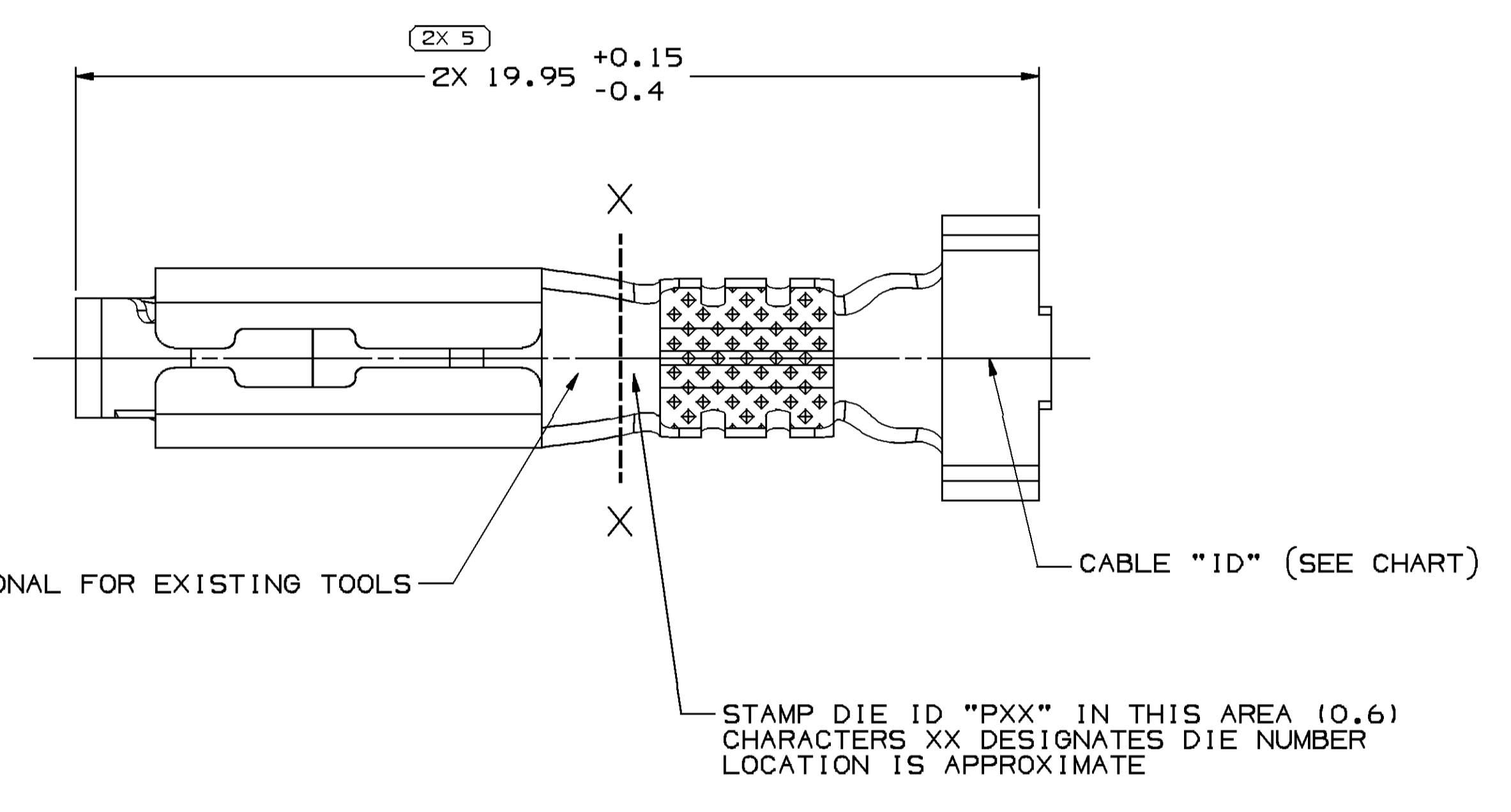

VIEW TO X-X

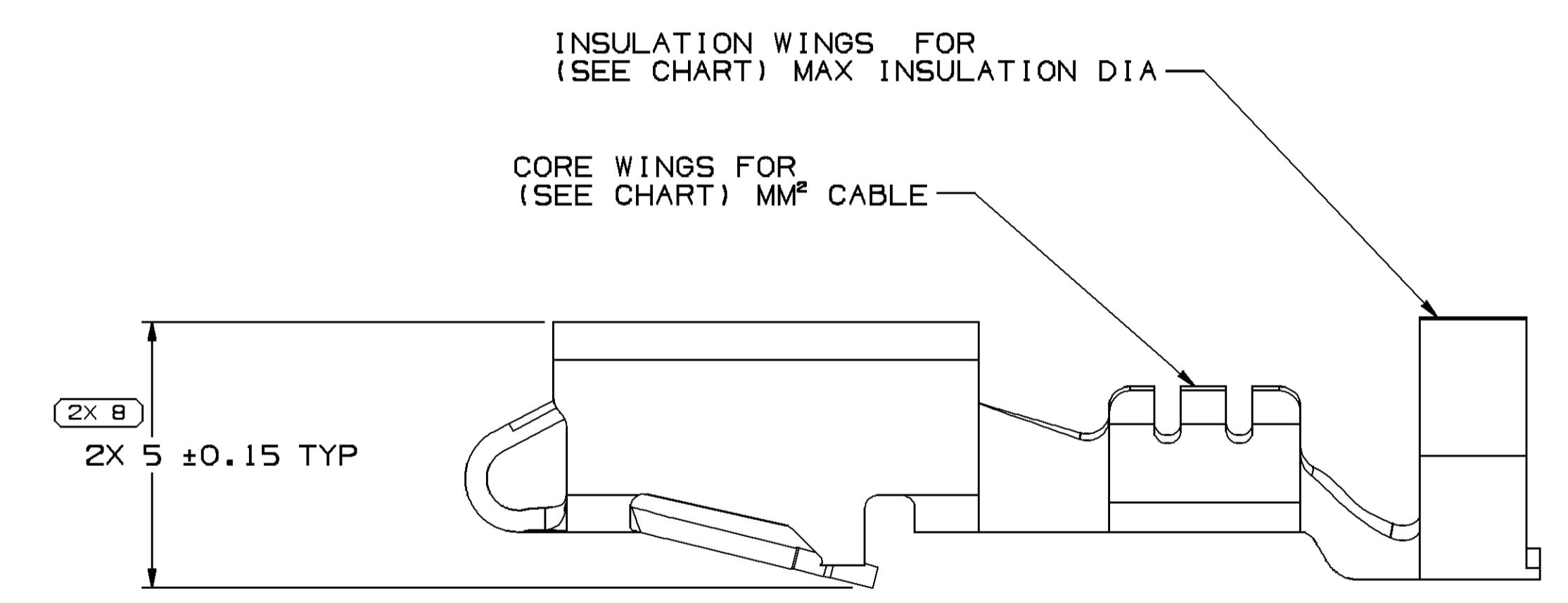

TYPE 101

- NOTES
- UNLESS OTHERWISE SPECIFIED AND/OR INDICATED: DIMENSIONS ARE TO FACE OF VIEW SHOWN AND AUTOMATICALLY ROUNDED BY COMPUTER FOR INSPECTION (SEE MATH MODEL FOR PRECISE DIMENSIONS). FOR ALL OTHER DIMENSIONS NOT SHOWN BUT REQUIRED FOR TOOL BUILD, SEE MATH MODEL FOR PRECISE TOOL PATH DATA.
  - R 0.4 PERMISSIBLE ON ALL "SHARP" CORNERS
  - RECOMMENDED MATING BLADE 2.8 X 0.81.
  - TERMINALS TO CRIMP AROUND AND RETAIN CAVITY SEAL 12015323 OR EQUIVALENT.
  - "PXX" INDICATES "P" PLUS LAST TWO DIGITS OF MAKE SERIES NUMBER (PO1, PO2, PO3, ETC.).
  - DO NOT PROBE, TEST OR OTHERWISE CONTACT THE INTERIOR REGION (THE SPRING OR ANY MOVING PART) OF THIS TERMINAL. SEVERE DAMAGE CAN OCCUR, COMPROMISING THE PERFORMANCE OF THE ELECTRICAL INTERFACE.
  - FOR TERMINALS PACKAGED & STORED IN THE APPROVED MANNER, TARNISH ON SILVER PLATED SURFACES WILL NOT AFFECT THE PERFORMANCE OF THE PART.

PART NO	REV	MAT'L SIZE	SPEC	PART NO	REV/N/P	MAT'L SPEC	SIZE (MM²)	CABLE	ID	TYPE
-	-	0.406 X 30.56	-	12176390	AB	-	AG PLATED COPPER ALLOY	0.35-0.5	0.35-0.5	21 103 2.4±0.2
-	-	-	-	12176389	A9	-	AG PLATED COPPER ALLOY	0.8-1	2.03-3.12	19 101 3.2±0.4
-	-	0.406 X 30.56	-	33231919	O1	-	AG PLATED COPPER ALLOY	1-2	2.48-3.05	15 103 3.7±0.4
-	-	0.406 X 30.56	-	12176388	AB	-	AG PLATED COPPER ALLOY	2-3	2.45-3.80	13 103 4±0.4
-	-	0.406 X 30.56	-	12176387	AB	-	AG PLATED COPPER ALLOY	5	3.49-3.65	12 103 4.6±0.4
-	-	0.406 X 30.56	-	12129493	CB	-	TIN PLATED COPPER ALLOY	2-3	2.45-3.80	13 103 4±0.4
-	-	0.406 X 30.56	-	12084201	E11	-	TIN PLATED COPPER ALLOY	0.35-0.5	1.84-2.51	21 101 2.4±0.2
-	-	0.406 X 30.56	-	12077413	E11	-	TIN PLATED COPPER ALLOY	3	3.49-3.65	12 103 4.6±0.4
-	-	0.406 X 30.56	-	12077412	E9	-	TIN PLATED COPPER ALLOY	1-2	2.48-3.05	15 103 3.7±0.4
-	-	0.406 X 30.56	-	12077411	E11	-	TIN PLATED COPPER ALLOY	0.5-0.8-1.0	2.03-3.12	19 101 3.2±0.4
-	-	0.406 X 32.54	-	12045639	DB	-	P1519027 425 TIN BRS EX HD SN PLTD	3	3.49-3.65	12 102 4.6±0.4
-	-	0.406 X 32.54	-	12034454	FB	-	P1519027 425 TIN BRS EX HD SN PLTD	1-2	2.48-3.05	15 102 3.7±0.4
-	-	0.406 X 32.54	-	12026648	HB	-	P1519027 425 TIN BRS EX HD SN PLTD	0.5-0.8	2.03-3.12	19 101 3.2±0.4
PART NO	REV	MAT'L SIZE	SPEC	PART NO	REV/N/P	MAT'L SPEC	SIZE (MM²)	CABLE	ID	TYPE
		UNPLATED								

**DELPHI**  
DELPHI PACKARD ELECTRICAL/ELECTRONIC ARCHITECTURE  
WARREN, OH  
COPYRIGHT 1998 DELPHI CORPORATION AND/OR ITS AFFILIATES. ALL RIGHTS RESERVED.  
THIS DRAWING IS THE PROPERTY OF DELPHI CORPORATION AND CONTAINS DELPHI CONFIDENTIAL INFORMATION. THE REPRODUCTION, DISTRIBUTION AND UTILIZATION OF THIS DOCUMENT OR ITS CONTENTS OR DATA, AS WELL AS COMMUNICATION OF ANY CONTENT TO OTHERS, WITHOUT EXPRESS AUTHORIZATION, IS PROHIBITED.

DATE: 16JUL98  
OR: OSCAR OCHOA  
APV02: OSCAR OCHOA  
APV03: O. GALLEGOS  
APV04:

THIS DOCUMENT IS IN ACCORDANCE WITH ASME Y14.5M-1994 AS MODIFIED BY THE 1995 SUPPLEMENT AND TELEPHONING ADDENDUM-2001. SEPARATE PATTERNS OF FEATURES MAY BE SHOWN SEPARATELY REGARDLESS OF DATUM REFERENCES.

UNLESS OTHERWISE SPECIFIED  
ALL DIMENSIONS ARE IN MILLIMETERS

REFERENCE: UNLESS OTHERWISE SPECIFIED

THIRD ANGLE PROJECTION  
DO NOT SCALE  
USE MATH DATA

DRAWING NUMBER: TAXI TERM F M/P 280 SEALED  
12089195

SIZE: A0  
SCALE: 10:1  
FRAME NO: 1 OF 1  
SHEET NO: 1 OF 1  
REV: R  
N/P: 08

Date: 05-Nov-15 Time: 11:14

SYMBOL DEFINITION		TOTAL NO OF INSPECTIONS REQUIRED	
A DIMENSION WITHOUT AN INSPECTION REPORT SYMBOL DOES NOT REQUIRE INSPECTION. IT MAY BE CONTROLLED ON THE INDIVIDUAL COMPONENT DRAWING.		10	
	LAST NO. USED	10	

DWG STATUS				REVISION HISTORY				AUTH		DR		APVD	
DATE	STG	REV	W/P	CHG	ZONE								
14JAO0	R	001	-	-		CLEARED REV COLUMN: ALL ACTIVE PARTS-UPDATED PDM ATTRIBUTES	196648	CRW	081	LLD			
17JL00	R	002	-	-		REINSTATE 12077412	000010	JIB	JIB	JA			
150C04	R	03	-	-		ALL ACTIVE PARTS - ADDED TERMINAL ID NOTE	260003	RTV	JVM	MKM			
24FE05	R	04	-	-		ALL ACTIVE PARTS - REVISED MAT'L SPEC & DRAWING NAME	265136	JS	JS	TM			
18MY05	R	05	-	-		12176389 - UPDATED PDM ATTRIBUTES	268280	JBD	FKV	WTM			
30SE05	R	06	-	-		12077411, 12077413, 12084201, 12129493 & 12176389 - UPDATED PDM ATTRIBUTES; 12077411 - ADDED 1.0 MM² CABLE; ALL ACTIVE PARTS - ADDED NOTE# 6	272905	JTV	AUG	WTM			
11JAO8	R	07	-	-		ALL PARTS - 2X 5 +/-0.15 TYP WAS 2X 5 +/-0.01 TYP	403419	WHC	WHC	WTM			
18FE15	R	08	-	-		33231919 - RELEASED AND 12176387-90 - ADDED TARNISH NOTE	428904	NRM	JVM	DS			

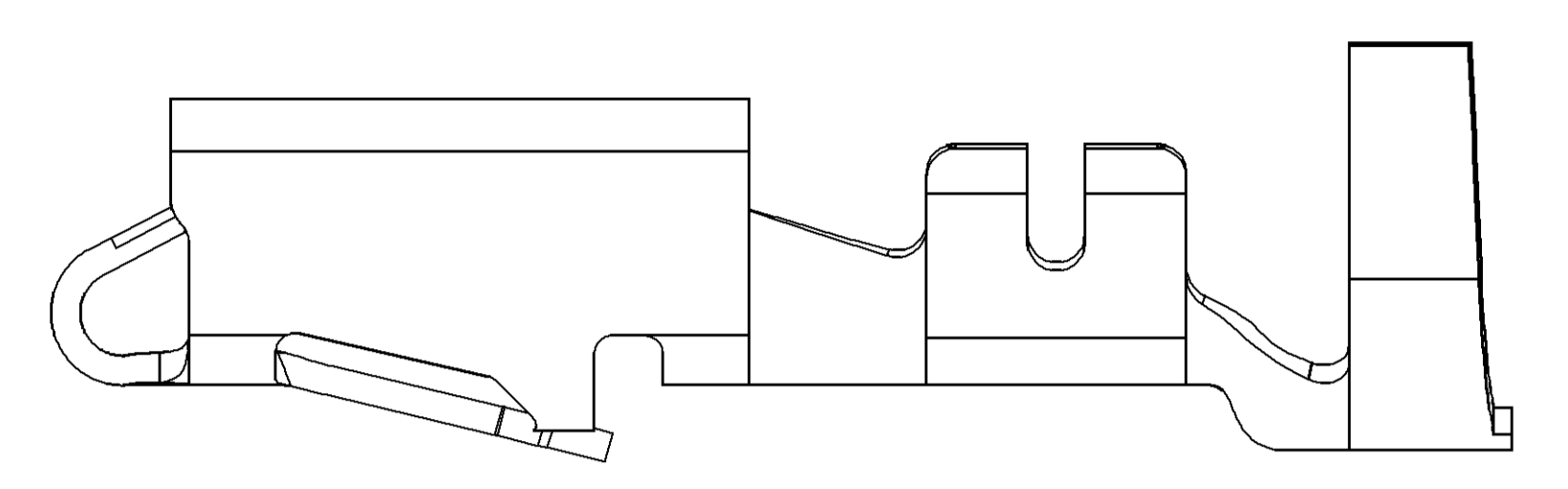

TYPE 102  
SAME AS TYPE 101  
EXCEPT AS SHOWN

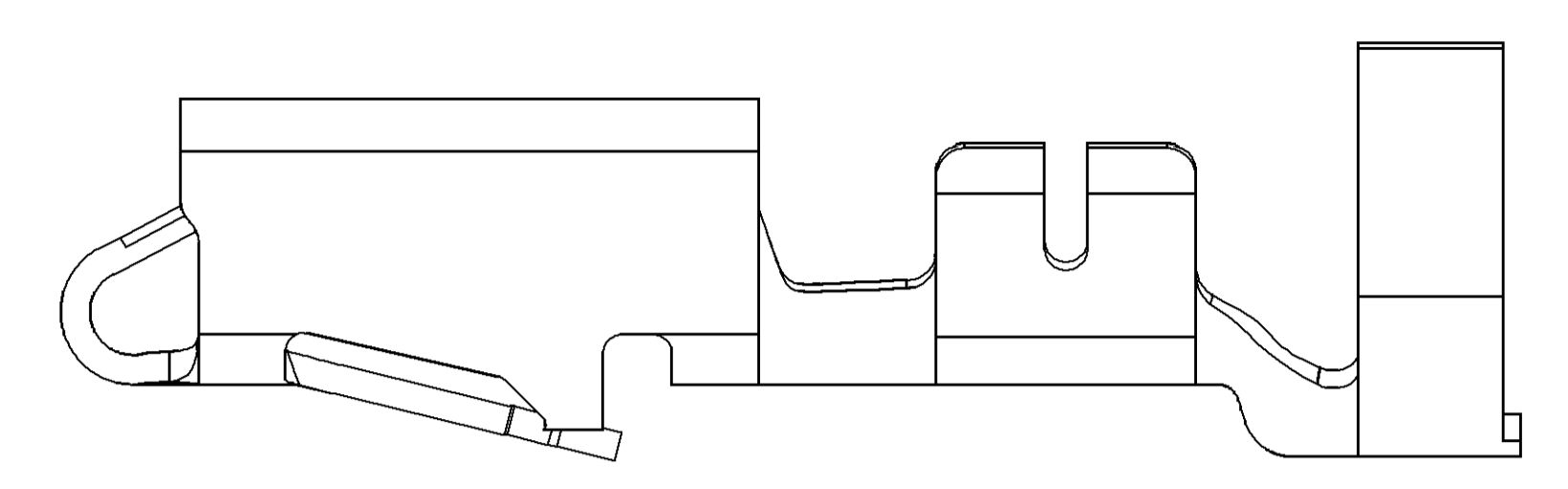

TYPE 103  
SAME AS TYPE 101  
EXCEPT AS SHOWN

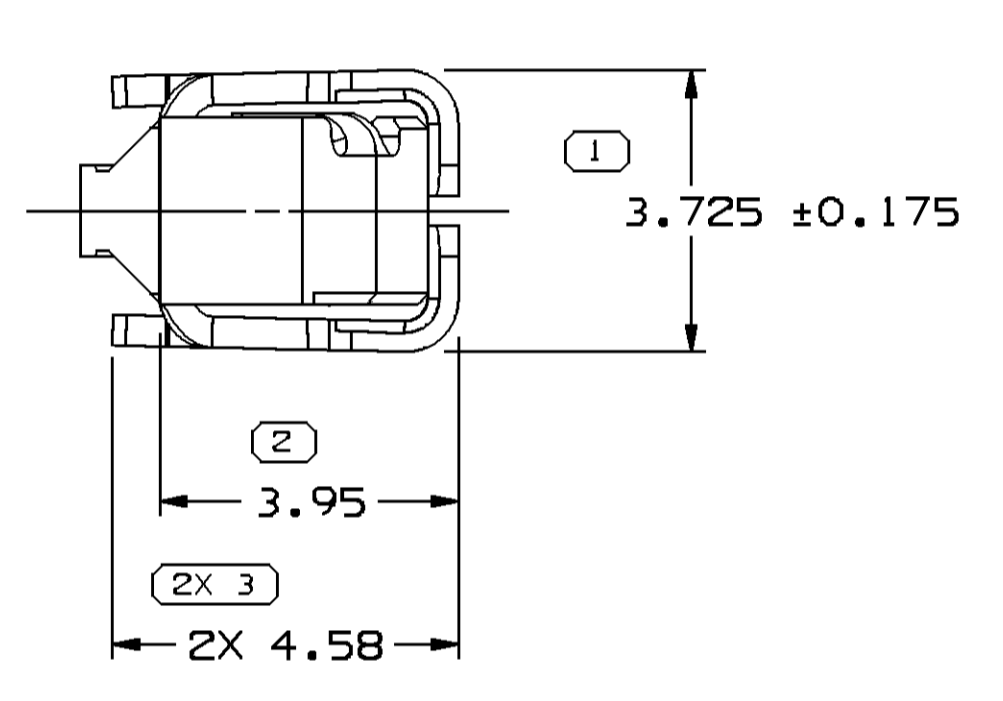
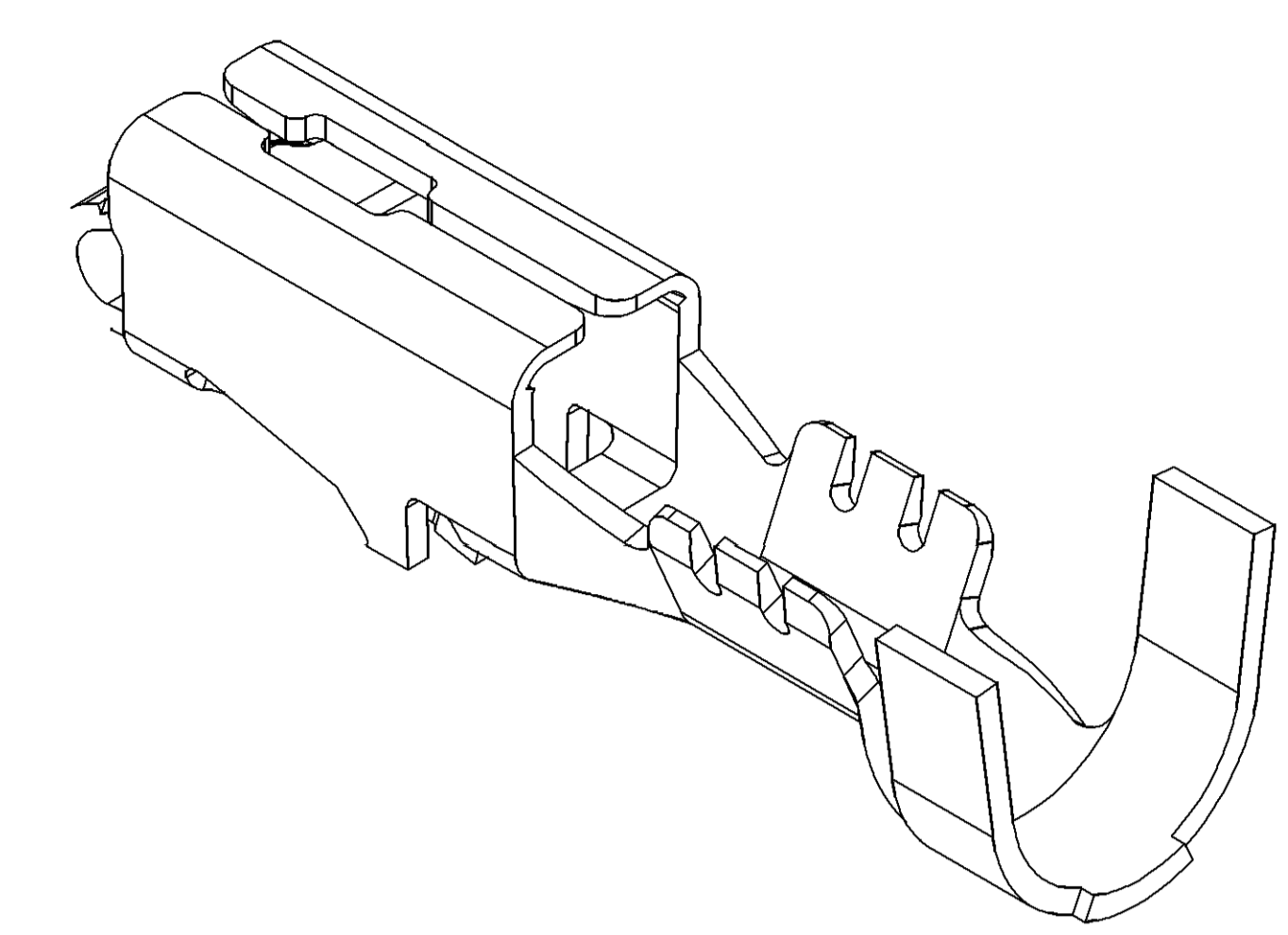

VIEW TO X-X

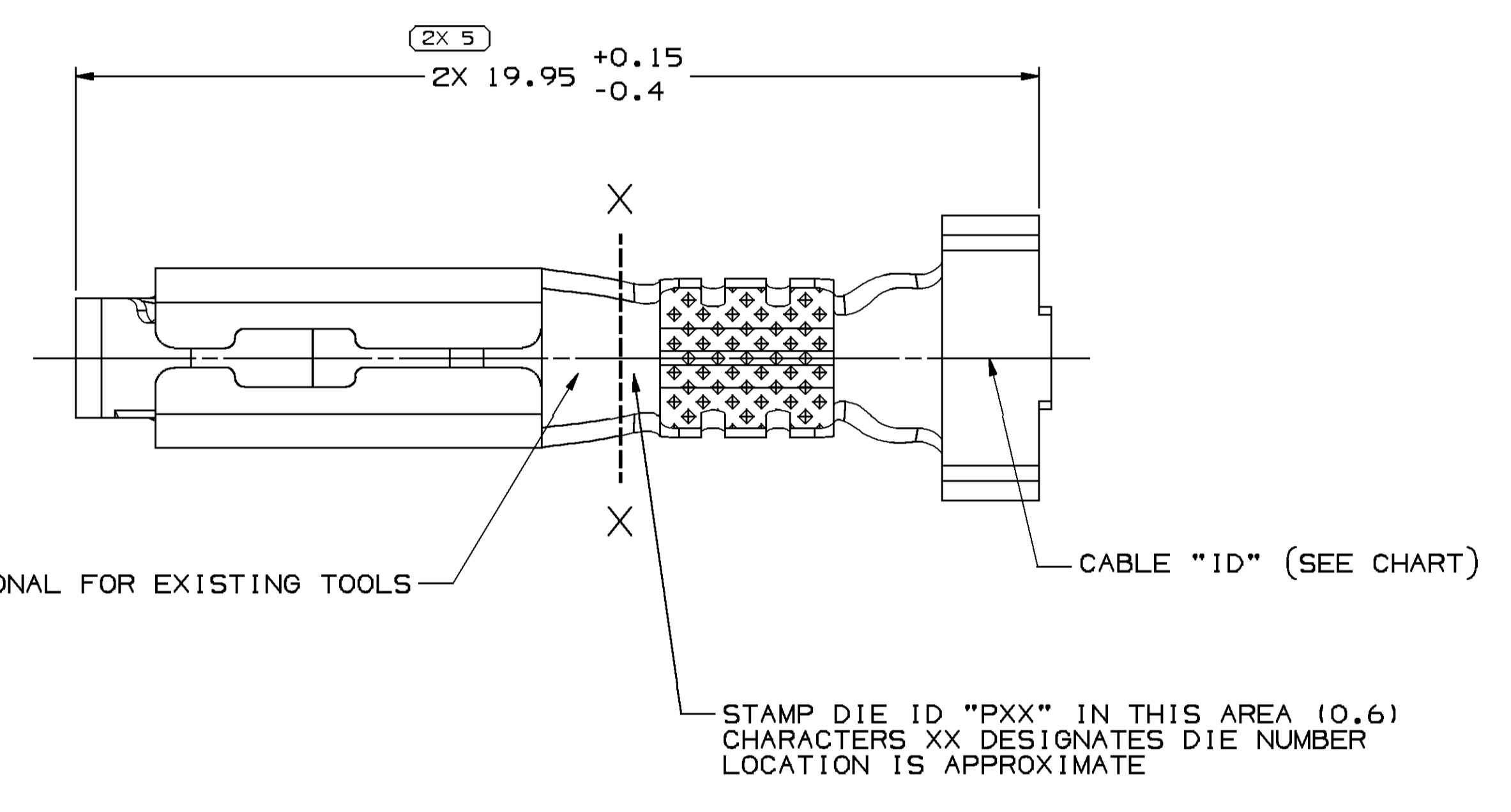

"PED" OPTIONAL FOR EXISTING TOOLS

CABLE "ID" (SEE CHART)

STAMP DIE ID "PXX" IN THIS AREA (0.6) CHARACTERS "XX" DESIGNATES DIE NUMBER LOCATION IS APPROXIMATE

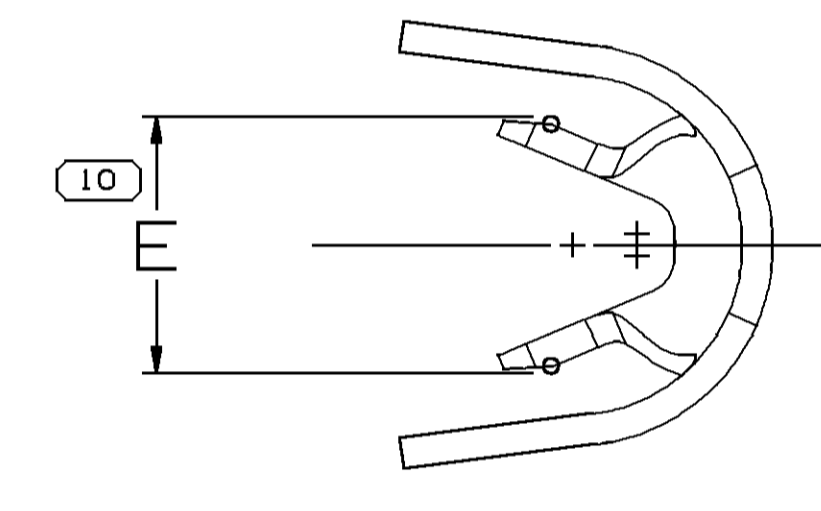

VIEW TO X-X

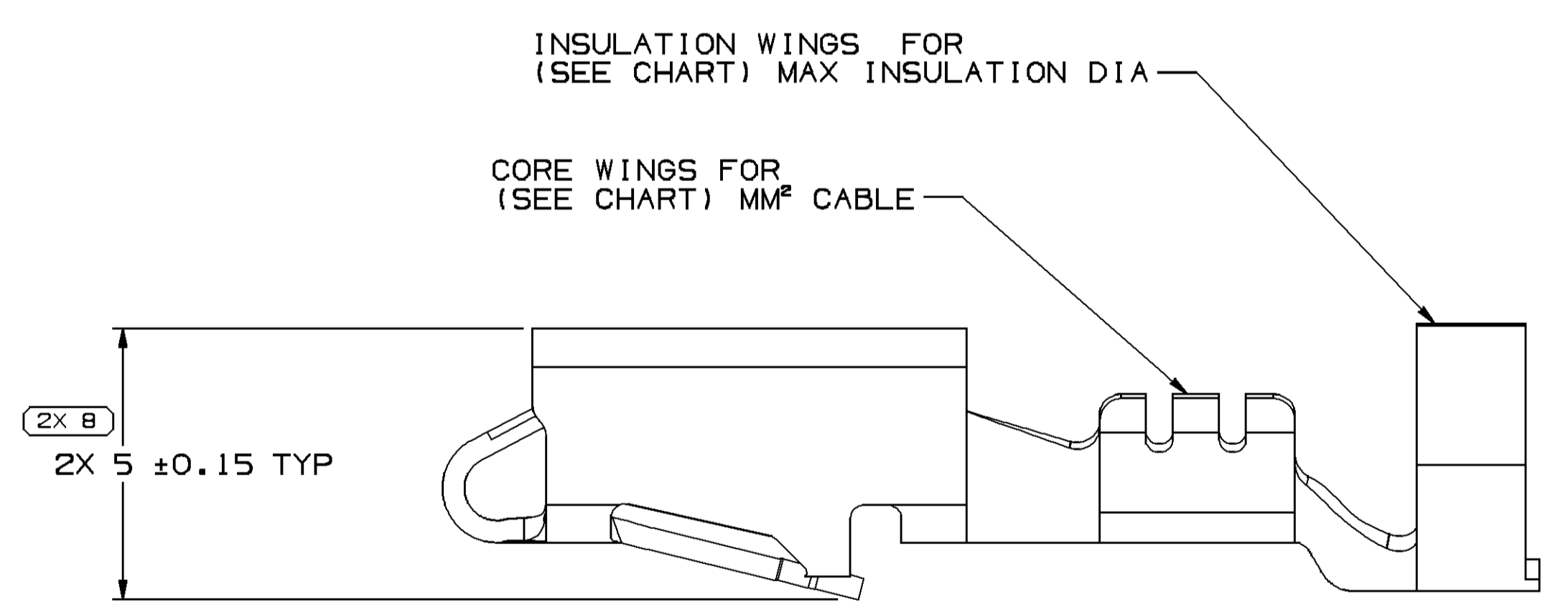

TYPE 101

- NOTES
- UNLESS OTHERWISE SPECIFIED AND/OR INDICATED: DIMENSIONS ARE TO FACE OF VIEW SHOWN AND AUTOMATICALLY ROUNDED BY COMPUTER FOR INSPECTION (SEE MATH MODEL FOR PRECISE DIMENSIONS). FOR ALL OTHER DIMENSIONS NOT SHOWN BUT REQUIRED FOR TOOL BUILD, SEE MATH MODEL FOR PRECISE TOOL PATH DATA.
  - R 0.4 PERMISSIBLE ON ALL "SHARP" CORNERS
  - RECOMMENDED MATING BLADE 2.8 X 0.81.
  - TERMINALS TO CRIMP AROUND AND RETAIN CAVITY SEAL 12015323 OR EQUIVALENT.
  - "PXX" INDICATES "P" PLUS LAST TWO DIGITS OF MAKE SERIES NUMBER (PO1, PO2, PO3, ETC.).
  - DO NOT PROBE, TEST OR OTHERWISE CONTACT THE INTERIOR REGION (THE SPRING OR ANY MOVING PART) OF THIS TERMINAL. SEVERE DAMAGE CAN OCCUR, COMPROMISING THE PERFORMANCE OF THE ELECTRICAL INTERFACE.
  - FOR TERMINALS PACKAGED & STORED IN THE APPROVED MANNER, TARNISH ON SILVER PLATED SURFACES WILL NOT AFFECT THE PERFORMANCE OF THE PART.

PART NO	REV	MAT'L SIZE	SPEC	PART NO	REV/N/P	PLATED	MAT'L SPEC	SIZE (MM²)	CABLE	ID	TYPE	E
-	-	0.406 X 30.56	-	12176390	AB	-	AG PLATED COPPER ALLOY	0.35-0.5	0.35-0.5	21	103	2.4±0.2
-	-	-	-	12176389	A9	-	AG PLATED COPPER ALLOY	0.8-1	2.03-3.12	19	101	3.2±0.4
-	-	0.406 X 30.56	-	33231919	O1	-	AG PLATED COPPER ALLOY	1-2	2.48-3.05	15	103	3.7±0.4
-	-	0.406 X 30.56	-	12176388	AB	-	AG PLATED COPPER ALLOY	2-3	2.45-3.80	13	103	4±0.4
-	-	0.406 X 30.56	-	12176387	AB	-	AG PLATED COPPER ALLOY	5	3.49-3.65	12	103	4.6±0.4
-	-	0.406 X 30.56	-	12129493	CB	-	TIN PLATED COPPER ALLOY	2-3	2.45-3.80	13	103	4±0.4
-	-	0.406 X 30.56	-	12084201	E11	-	TIN PLATED COPPER ALLOY	0.35-0.5	1.84-2.51	21	101	2.4±0.2
-	-	0.406 X 30.56	-	12077413	E11	-	TIN PLATED COPPER ALLOY	3	3.49-3.65	12	103	4.6±0.4
-	-	0.406 X 30.56	-	12077412	E9	-	TIN PLATED COPPER ALLOY	1-2	2.48-3.05	15	103	3.7±0.4
-	-	0.406 X 30.56	-	12077411	E11	-	TIN PLATED COPPER ALLOY	0.5-0.8-1.0	2.03-3.12	19	101	3.2±0.4
-	-	0.406 X 32.54	-	12045639	DB	-	P1519027 425 TIN BRS EX HD SN PLTD	3	3.49-3.65	12	102	4.6±0.4
-	-	0.406 X 32.54	-	12034454	FB	-	P1519027 425 TIN BRS EX HD SN PLTD	1-2	2.48-3.05	15	102	3.7±0.4
-	-	0.406 X 32.54	-	12026648	HB	-	P1519027 425 TIN BRS EX HD SN PLTD	0.5-0.8	2.03-3.12	19	101	3.2±0.4

**DELPHI**  
DELPHI PACKARD ELECTRICAL/ELECTRONIC ARCHITECTURE  
WARREN, OH  
COPYRIGHT 1998 DELPHI CORPORATION AND/OR ITS AFFILIATES. ALL RIGHTS RESERVED.  
THIS DRAWING IS THE PROPERTY OF DELPHI CORPORATION AND CONTAINS DELPHI CONFIDENTIAL INFORMATION. THE REPRODUCTION, DISTRIBUTION AND UTILIZATION OF THIS DOCUMENT OR ITS CONTENTS OR DATA, AS WELL AS COMMUNICATION OF ANY CONTENT TO OTHERS, WITHOUT EXPRESS AUTHORIZATION, IS PROHIBITED.

DATE: 16JUL98

OR: JORGE IBARRA, OSCAR OCHOA, O. GALLEGOS

29MY98, 02JUN98, 16JUL98

UNLESS OTHERWISE SPECIFIED THIS DOCUMENT IS IN ACCORDANCE WITH ASME Y14.5M-1994 AS INDICATED BY THE DIMENSIONAL DRIVING AND TELEGRAPHING ADDENDUM-2001. SEPARATE PATTERNS OF FEATURES MAY BE SHOWN SEPARATELY REGARDLESS OF DATUM REFERENCES.

ALL DIMENSIONS ARE IN MILLIMETERS

REFERENCE: UNLESS OTHERWISE SPECIFIED

THIRD ANGLE PROJECTION

DO NOT SCALE USE MATH DATA

DRAWING NUMBER: TAXI TERM F M/P 280 SEALED

DRAWING NUMBER: 12089195

SIZE: A0 SCALE: 10:1 FRAME NO: 1 OF 1 SHEET NO: 1 OF 1 STG: REV: N/P: R 08 -

Date: 05-Nov-15 Time: 11:14