

# M 776430-3



*Proseguire nella pagina successiva per visualizzare la scheda tecnica dei componenti*

Revisione	Prodotto
REV.00 16/04/2026	OEM

THIS DRAWING IS UNPUBLISHED. RELEASED FOR PUBLICATION  
 © COPYRIGHT 20 BY - ALL RIGHTS RESERVED.

REVISIONS					
P	LTR	DESCRIPTION	DATE	DWN	APVD
E		REVISED PER ECO-13-019095	05DEC2013	DR	RB
EI		REVISED PER PCN-23-190965	31OCT2023	AP	CB

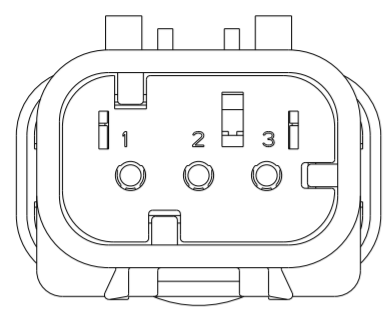

776430-2  
SCALE 2:1  
KEY B

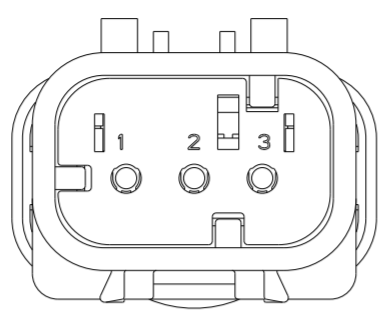

776430-3  
SCALE 2:1  
KEY C

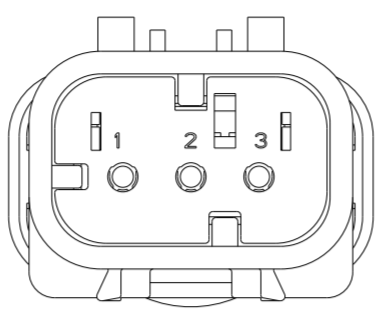

776430-4  
SCALE 2:1  
KEY D

- 1 MATERIAL: 15% GLASS FILLED THERMOPLASTIC  
COLOR: BLACK
- 2 MATERIAL: 15% GLASS FILLED THERMOPLASTIC  
COLOR: (SEE TABLE)
- 3 MATERIAL: SILICONE  
COLOR: GREEN
- 4. RECOMMENDED WIRE DIAMETER RANGE IS 2.18 TO 3.67mm.

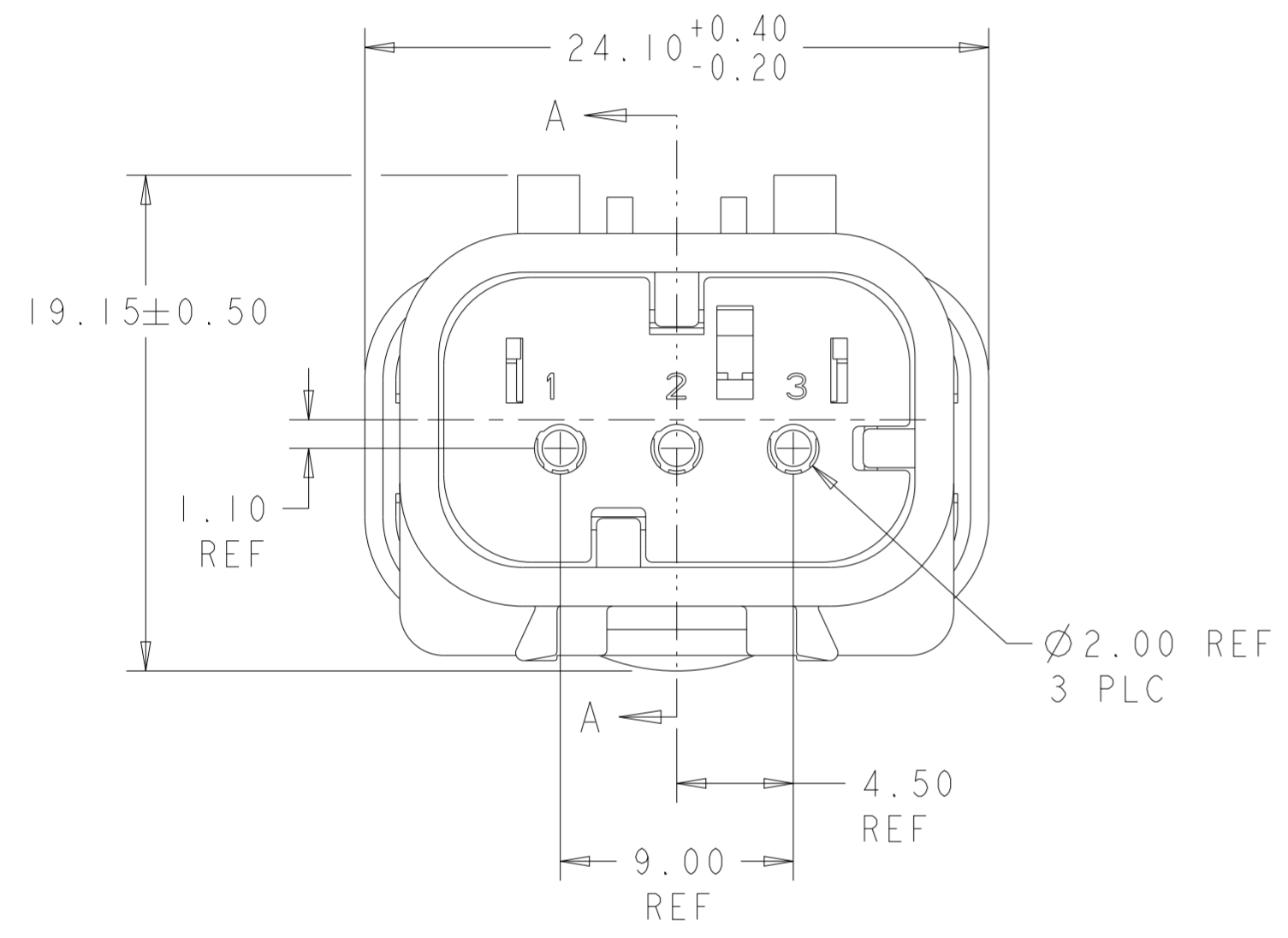

776430-1 SHOWN  
KEY A

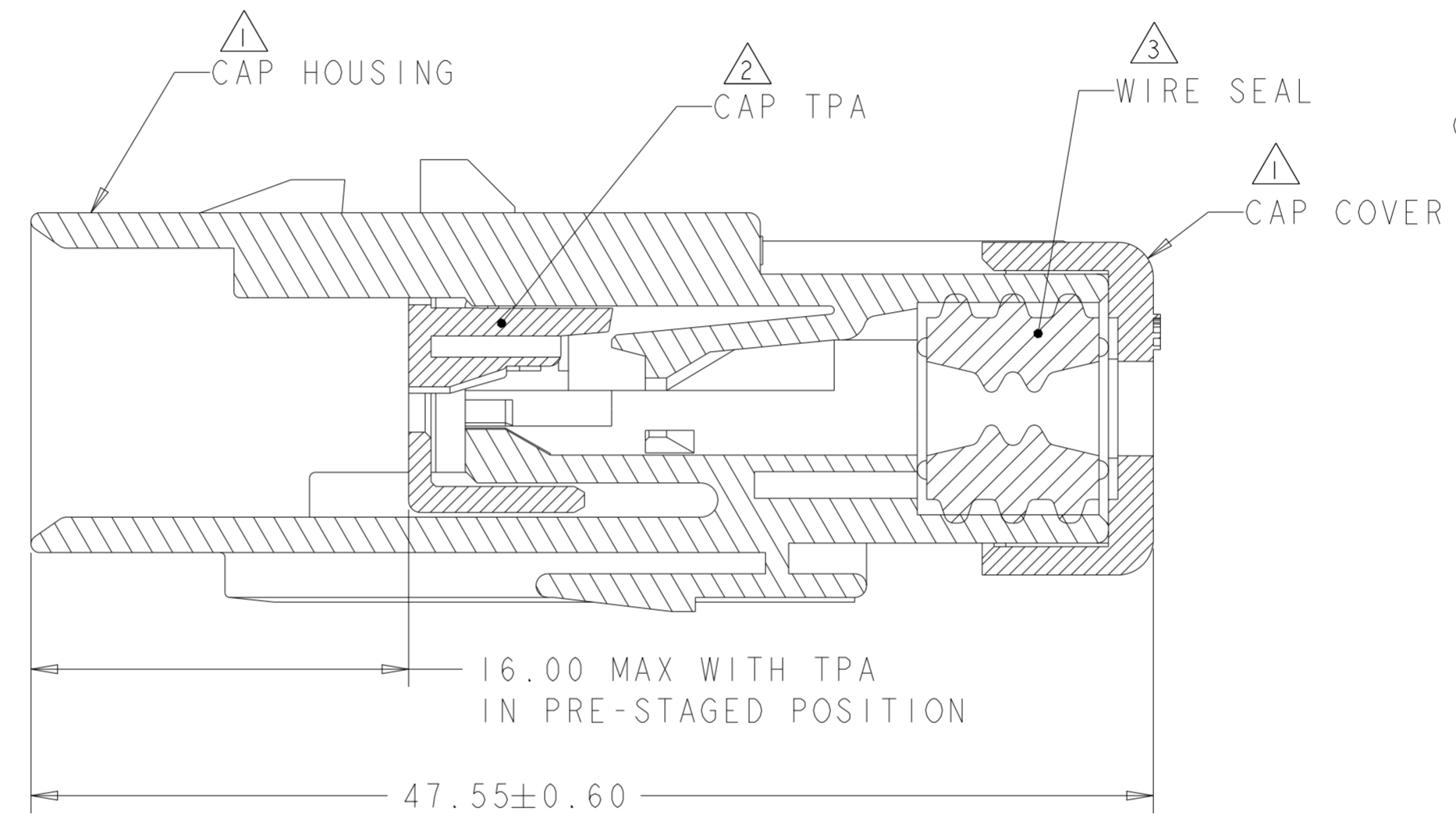

SECTION A-A

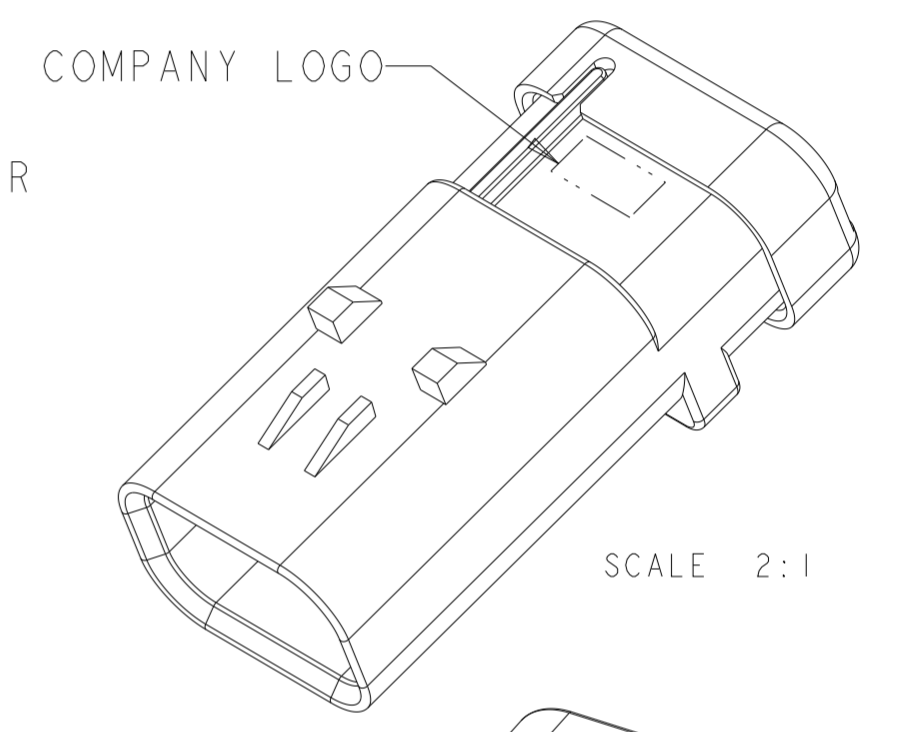

SCALE 2:1

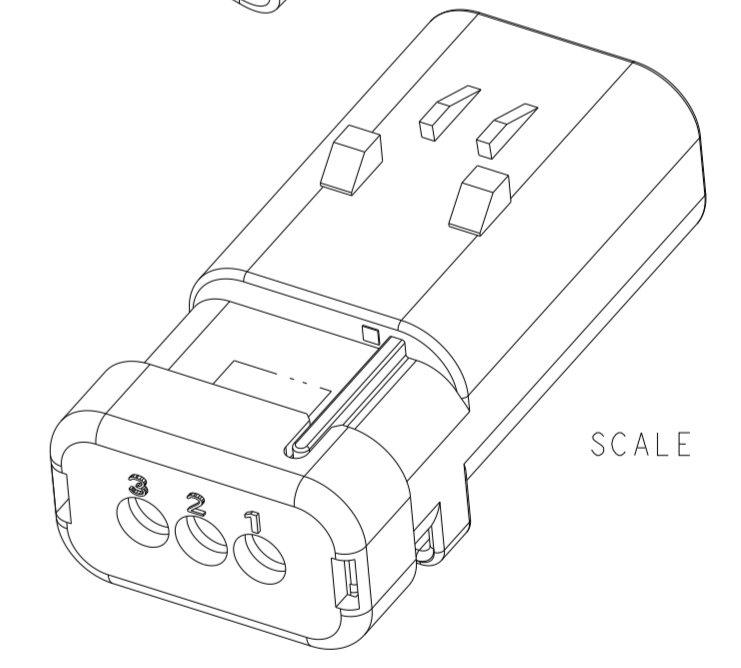

SCALE 2:1

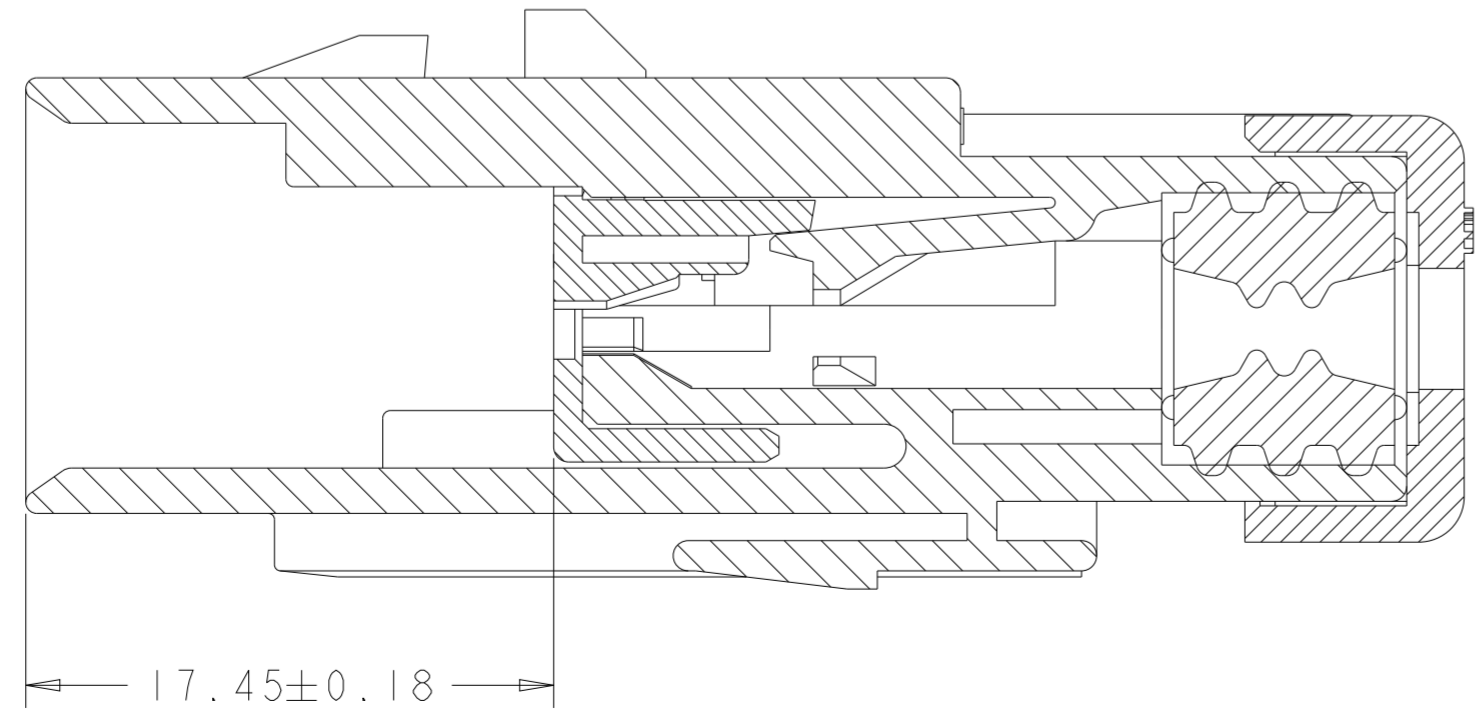

SECTION A-A  
WITH TPA IN CLOSED POSITION

D	GREEN	776430-4
C	YELLOW	776430-3
B	GRAY	776430-2
A	RED	776430-1
KEY	TPA COLOR	PART NUMBER

THIS DRAWING IS A CONTROLLED DOCUMENT.		DWN Y. PETERSON	22FEB00	TE Connectivity	
DIMENSIONS: mm		CHK R. GREINER	11DEC01		
TOLERANCES UNLESS OTHERWISE SPECIFIED:		APVD M. TRULL	11DEC01		
0 PLC ± 1 PLC ± 2 PLC ± 3 PLC ± 4 PLC ± ANGLES ± FINISH -		PRODUCT SPEC 108-2184	APPLICATION SPEC 114-13065		
MATERIAL		WEIGHT	10	SIZE A2	CAGE CODE 00779
		Customer Drawing		DRAWING NO C-776430	RESTRICTED TO -
		SCALE	4:1	SHEET	OF
				REV	EI