

M 776522-1



Proseguire nella pagina successiva per visualizzare la scheda tecnica dei componenti

Revisione	Prodotto
REV.00 14/04/2026	OEM

THIS DRAWING IS UNPUBLISHED. RELEASED FOR PUBLICATION 20
 © COPYRIGHT 20 BY - ALL RIGHTS RESERVED.

REVISIONS				
P	LTR	DESCRIPTION	DATE	APVD
E		REVISED PER ECO-13-019067	05DEC2013	DR RB

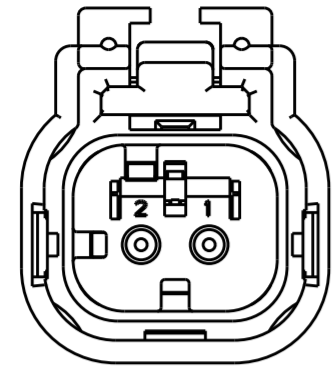

776522-2
SCALE 2:1
KEY B

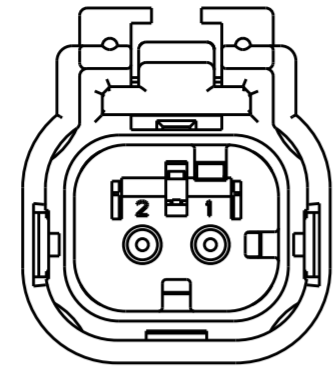

776522-3
SCALE 2:1
KEY C

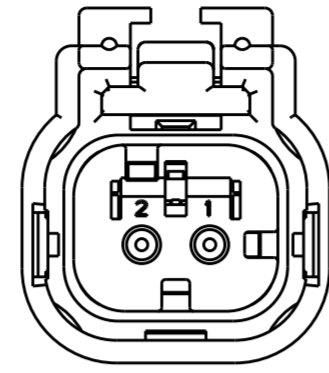

776522-4
SCALE 2:1
KEY D

- 1 MATERIAL: 15% GLASS FILLED THERMOPLASTIC
COLOR: BLACK
- 2 MATERIAL: 15% GLASS FILLED THERMOPLASTIC
COLOR: (SEE TABLE)
- 3 MATERIAL: SILICONE
COLOR: LIGHT GRAY
- 4 MATERIAL: 15% GLASS FILLED THERMOPLASTIC
COLOR: RED
- 5. RECOMMENDED WIRE DIAMETER RANGE IS 1.30 TO 2.54mm.
- 6 MATERIAL: SILICONE
COLOR: BLUE

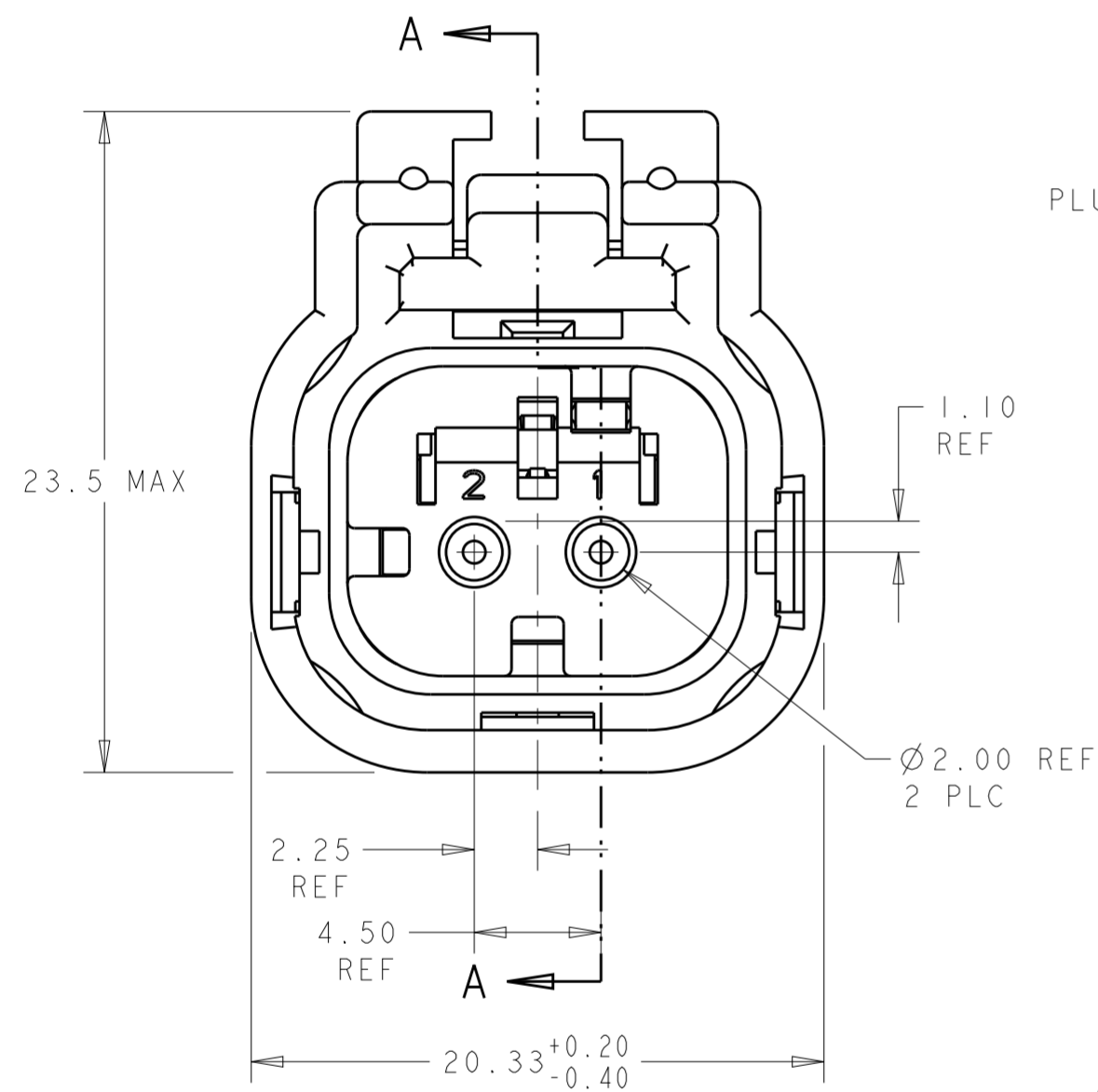

776522-1 SHOWN
KEY A

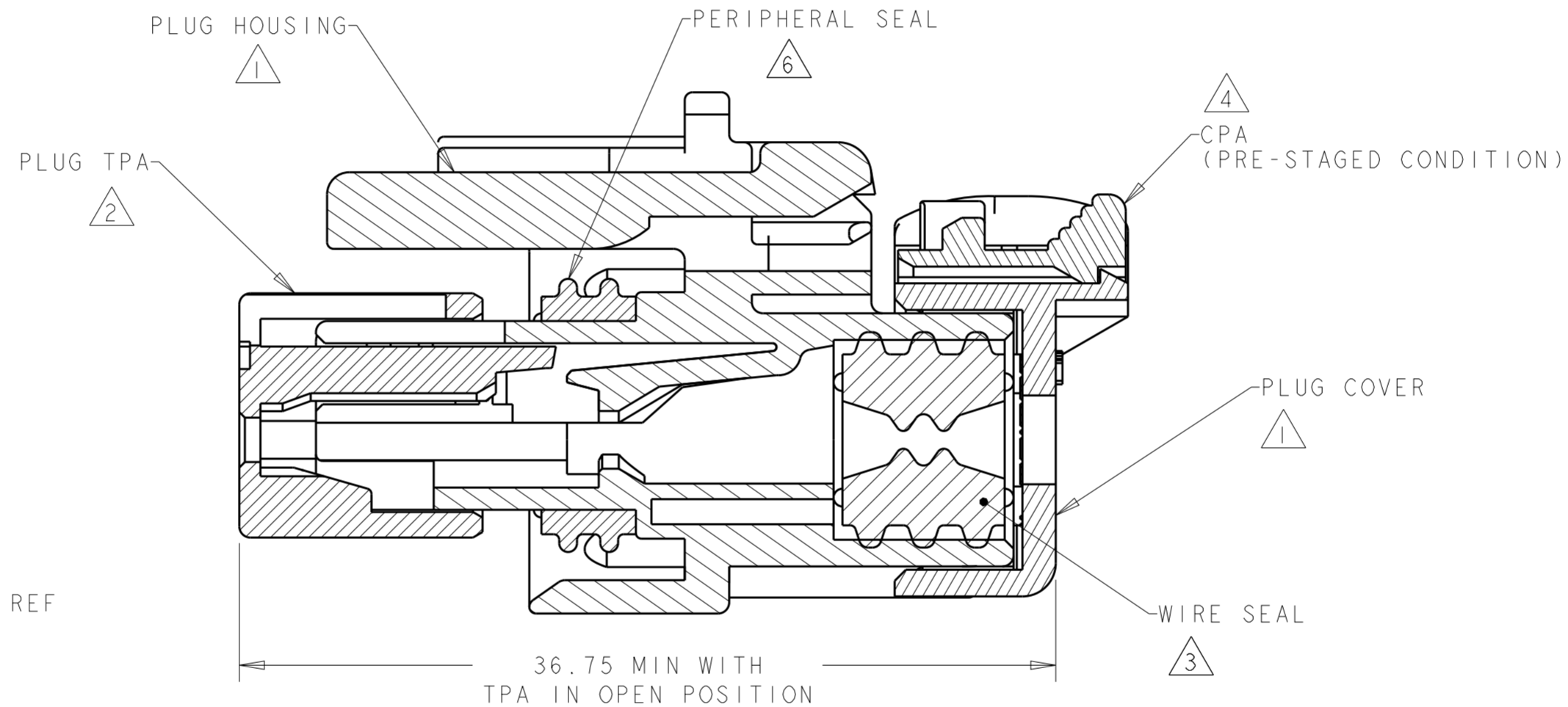

SECTION A-A

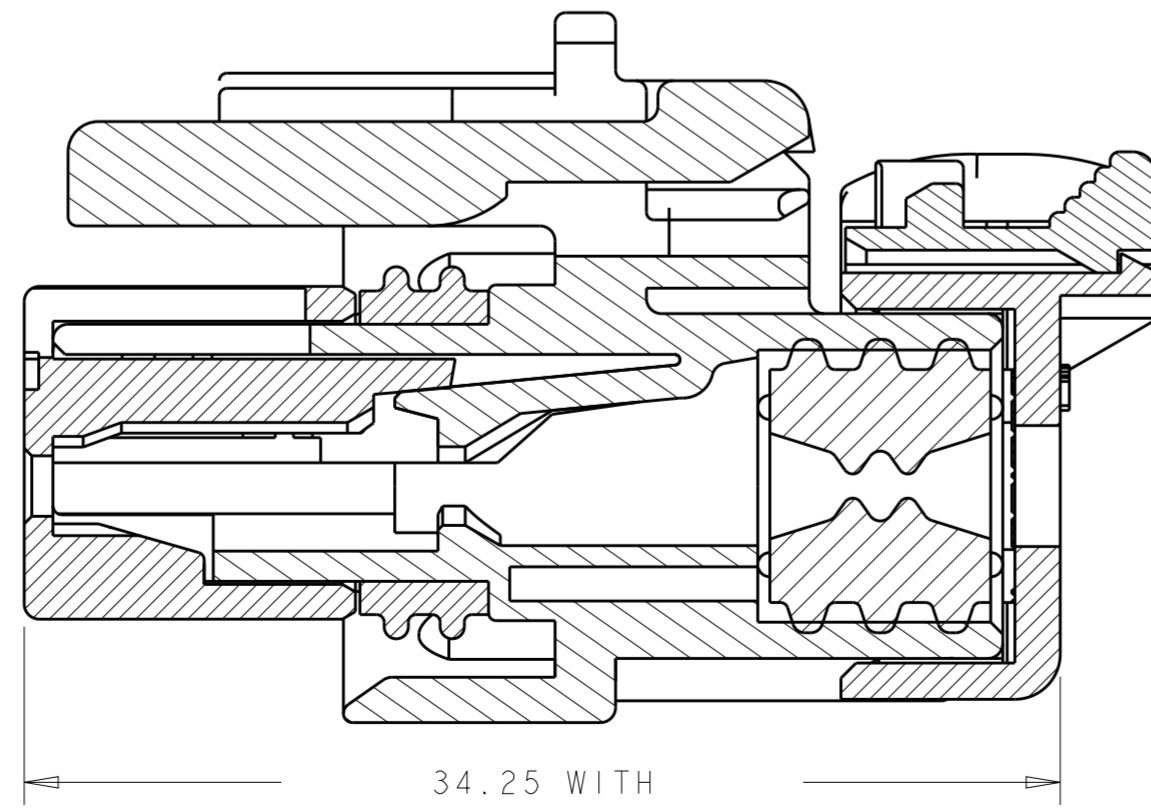

SECTION A-A

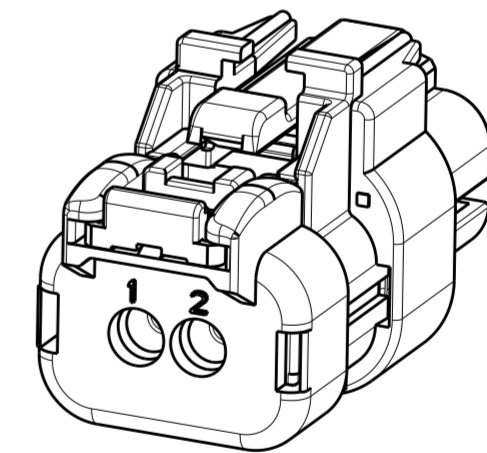
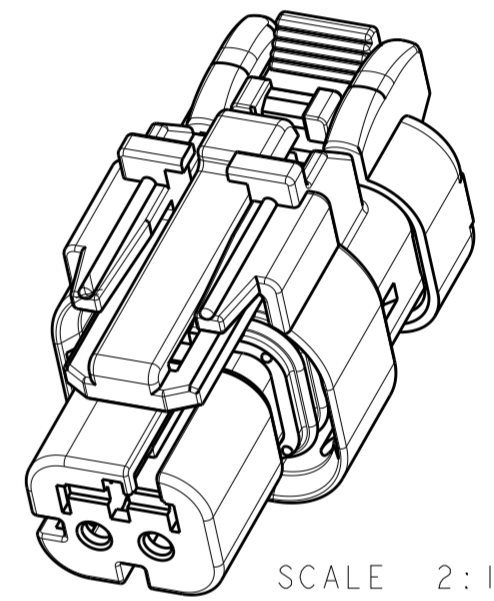

D	GREEN	776522-4
C	YELLOW	776522-3
B	GRAY	776522-2
A	RED	776522-1
KEY	TPA COLOR	PART NUMBER

THIS DRAWING IS A CONTROLLED DOCUMENT.

DIMENSIONS:		TOLERANCES UNLESS OTHERWISE SPECIFIED:	
mm		0 PLC	±
		1 PLC	±
		2 PLC	±
		3 PLC	±
		4 PLC	±
		ANGLES	±
		FINISH	-
			-

DWN	AJ GRAFF	22FEB00
CHK	R GREINER	11DEC01
APVD	M TRULLI	11DEC01
PRODUCT SPEC	108-2184	
APPLICATION SPEC	114-13065	
WEIGHT	8	
Customer Drawing		

STE TE Connectivity			
NAME PLUG ASSEMBLY, 2 POSITION, SINGLE ROW REDUCED DIA WIRE SEAL, AMPSEAL 16			
SIZE	CAGE CODE	DRAWING NO	RESTRICTED TO
A2	0779	C-776522	-
SCALE	4:1	SHEET	OF
			REV E